

Graph Theory for Network Science

Dr. Natarajan Meghanathan
Associate Professor
Department of Computer Science
Jackson State University, Jackson, MS
E-mail: natarajan.meghanathan@jsums.edu

Networks or Graphs

- We typically use the terms interchangeably.
- **Networks** – refers to real systems
 - WWW: network of web pages connected by URLs
 - Society: network of individuals connected by family, friendship or professional ties
 - Metabolic network: sum of all chemical reactions that take place in a cell
- **Graphs**: Mathematical representation of the networks
 - Web graph, Social graph, Metabolic graph

Network Science	Graph Theory
network	graph
node	vertex
link	edge

Real systems of quite different nature can have the same network representation

- Even though these real systems have different nature, appearance or scope, they can be represented as the same network (graph)
- Internet – connected using routers
- Actor network – network of actors who acted together in at least one movie
- Protein-Protein Interaction (PPI) network – two proteins are connected if there is experimental evidence that they can bind each other in the cell

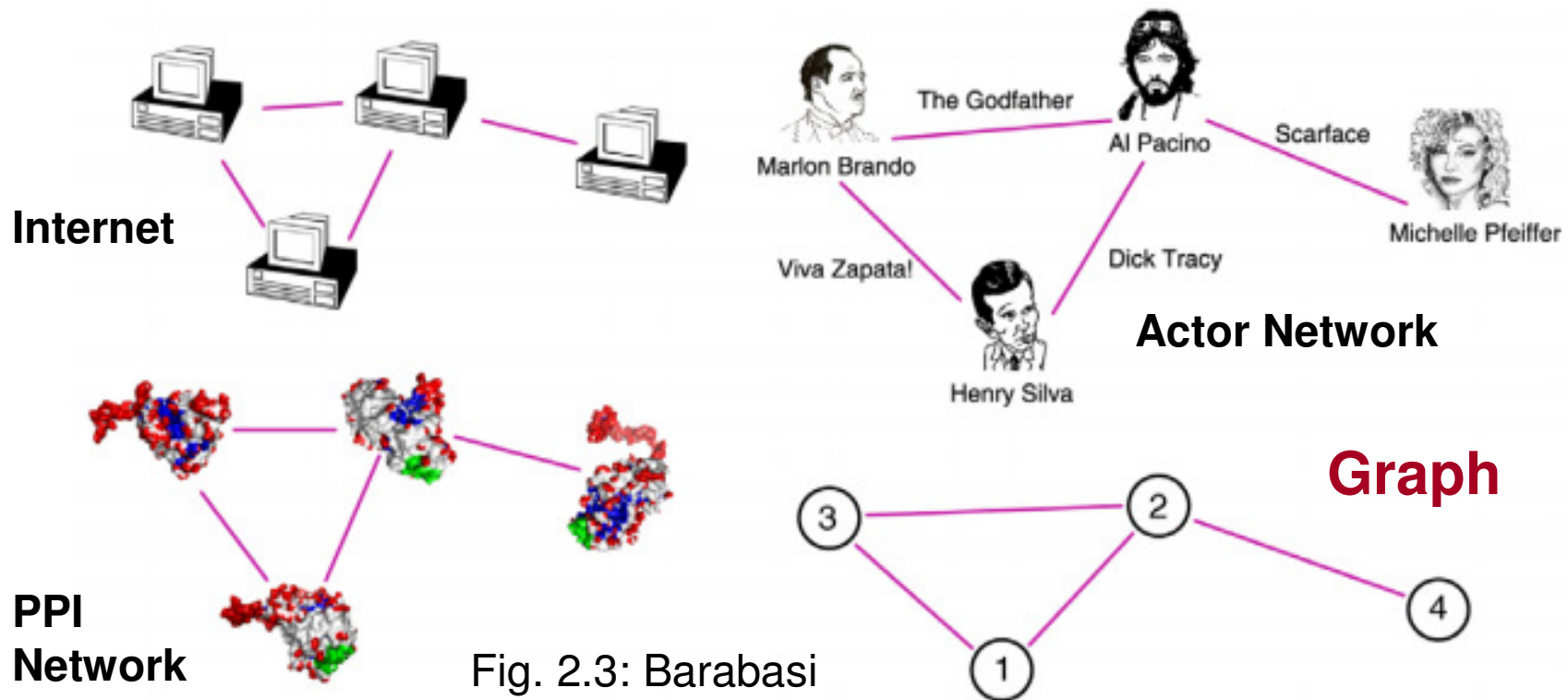

Fig. 2.3: Barabasi

Networks

- Node – Components in the system
 - Link – Interactions between the nodes
-
- Directed link – nodes that interact in a specific direction (A calling B, not vice-versa; URL A is linked to URL B; A likes B)
 - Undirected link – Transmission lines on the power grid (two people who are friends to each other in Facebook; electric current flowing in both directions; A and B are siblings; A and B are co-authors)
 - Degree of a node – Number of links incident on it
 - In-degree - # incoming links; Out-degree - # outgoing links
-
- Directed network – contains all directed links
 - Undirected network – contains all undirected links
 - Some networks can have both directed and undirected links
 - Metabolic network with certain reactions being reversible and certain reactions proceeding in only one direction
 - It is important to make proper choices in the selection of links to apply the network science theory.

Edge Attributes

- Weight (e.g., frequency of communication)
- Ranking (choice of dining parameters)
- Type (friend, relative, co-worker)

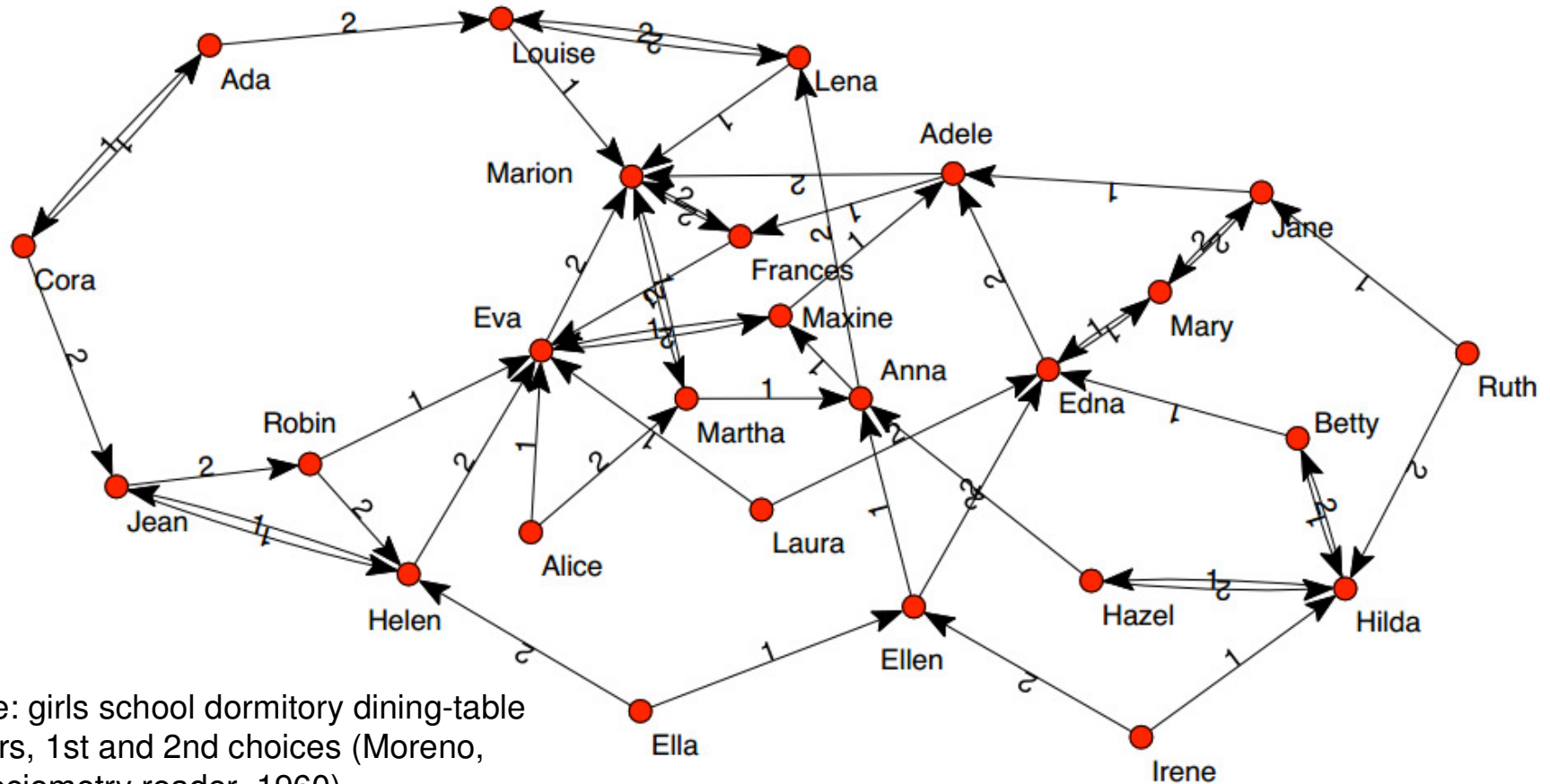

Source: girls school dormitory dining-table partners, 1st and 2nd choices (Moreno, The sociometry reader, 1960)

Degree and # Links

On a complete graph of N nodes, the max. number of links is

$$\frac{N(N-1)}{2}$$

Average Degree
= $N - 1$

- **Undirected network**

– Let k_i denote the degree of node i , then the total number of links is:

$$L = \frac{1}{2} \sum_{i=1}^N k_i$$

– The $\frac{1}{2}$ factor is because we count each link twice while computing the sum of the degrees

– The average degree of an undirected network

$$\langle k \rangle \equiv \frac{1}{N} \sum_{i=1}^N k_i = \frac{2L}{N}$$

For many large real-world networks, $\langle k \rangle \sim 1/N$, implying that the networks are sparse

Degree and # Links

- Directed Network

- Let k_i^{in} and k_i^{out} denote the incoming and outgoing degrees of node i .

- The total number of links:

$$L = \sum_{i=1}^N k_i^{in} = \sum_{i=1}^N k_i^{out}$$

- Average degree of a directed network is:

-

$$\langle k^{in} \rangle = \frac{1}{N} \sum_{i=1}^N k_i^{in} = \langle k^{out} \rangle = \frac{1}{N} \sum_{i=1}^N k_i^{out} = \frac{L}{N}$$

Common Network Maps: their Properties

<u>Network Name</u>	<u>Nodes</u>	<u>Links</u>	<u>Directed / Undirected</u>	<u># Nodes, N</u>	<u># Links, L</u>	<u>Average Degree, <K></u>
E. Coli Metabolism	Metabolites	Chemical reactions	Directed	1,039	5,802	5.58
Yeast Protein Interactions	Proteins	Binding interactions	Undirected	2,018	2,930	2.90
Power Grid	Power plants, Transformers	Cables	Undirected	4,941	6,594	2.67
Science Collaboration	Scientists	Co-authorships	Undirected	23,133	186,936	16.16
Mobile Phone Calls*	Subscribers	Calls	Directed	36,595	91,826	2.51
Email	Email addresses	Emails	Directed	57,194	103,731	1.81
Internet	Routers	Internet connections	Undirected	192,244	609,066	2.67
Actor network	Actors	Co-acting	Undirected	212,250	3,054,278	28.78
WWW *	Web pages	Links	Directed	325,729	1,497,134	4.60
Citation network	Papers	Citations	Directed	449,673	4,707,958	10.47

* - Subset of the real system

Degree Distribution $\sum_{k=1}^{\infty} p_k = 1$

- Let p_k denote the probability that a randomly selected node has degree k .
- For a fixed number of nodes (N) in the network, $p_k = N_k / N$, where N_k is the number of degree k nodes.
- Average degree of a network is:

$$\langle k \rangle = \sum_{k=0}^{\infty} kp_k$$

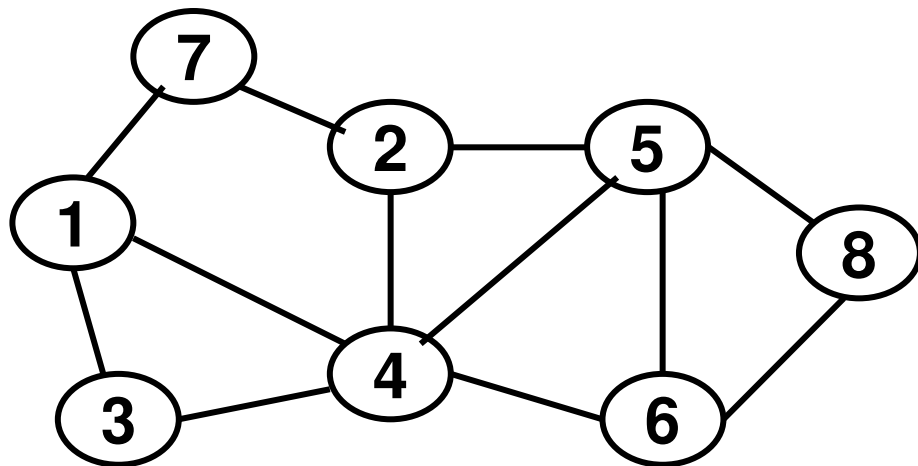

Nodes	Degree
1	3
2	3
3	2
4	5
5	4
6	3
7	2
8	2

Degree	# nodes
2	3
3	3
4	1
5	1

Degree	Prob[deg]
2	0.375
3	0.375
4	0.125
5	0.125

$$\begin{aligned} \text{Avg. Degree} &= (2 \cdot 0.375) + (3 \cdot 0.375) + (4 \cdot 0.125) + (5 \cdot 0.125) \\ &= 3.0 \end{aligned}$$

Degree Distribution Examples

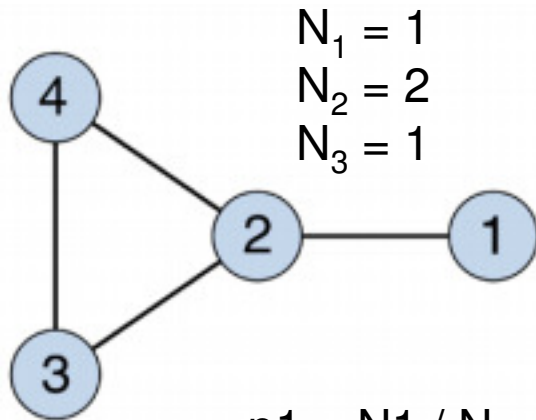

$$p_1 = N_1 / N = 1/4 = 0.25$$
$$p_2 = N_2 / N = 2/4 = 0.5$$
$$p_3 = N_3 / N = 1/4 = 0.25$$

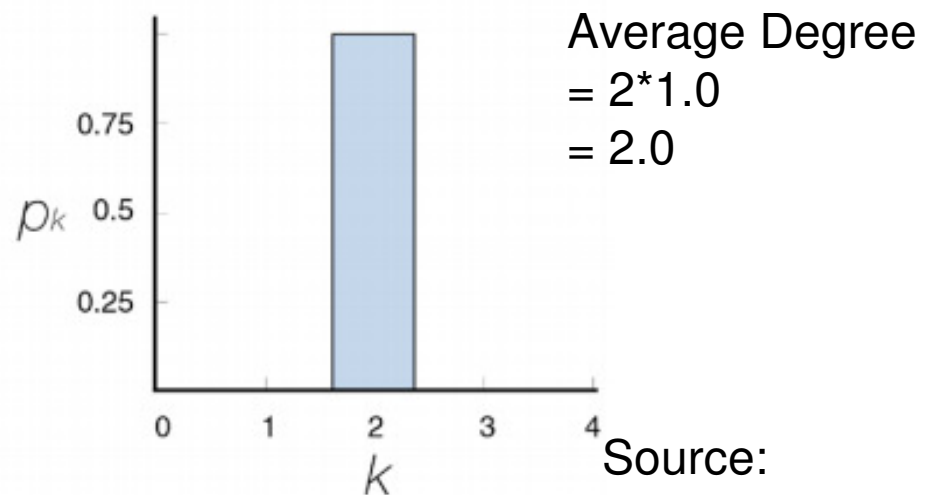
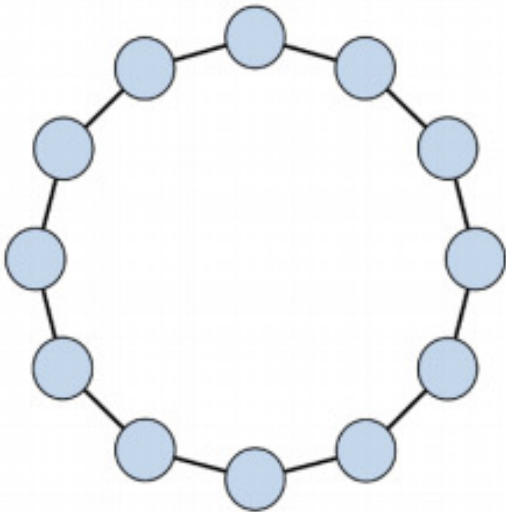
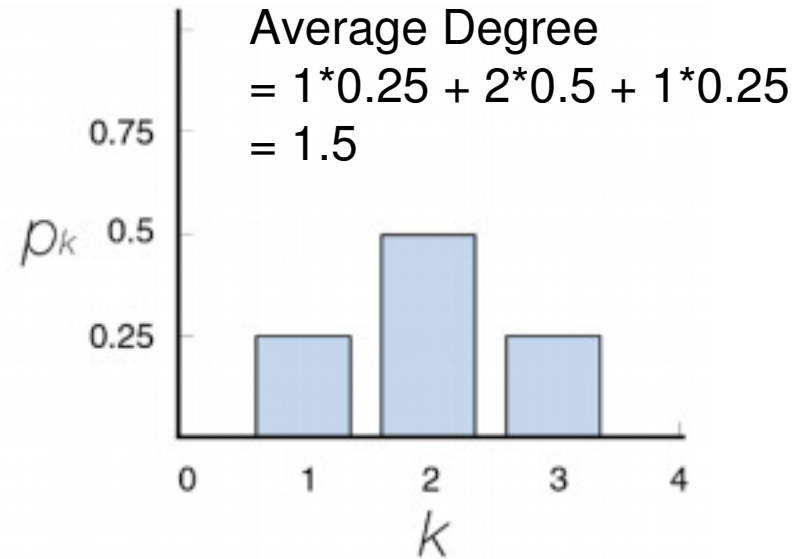

Source:
Figure 2.4a: Barabasi

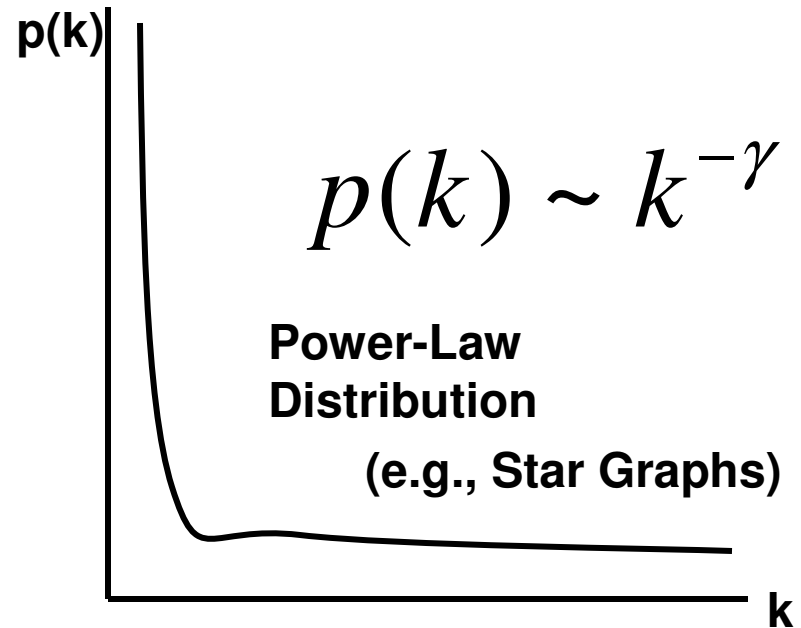
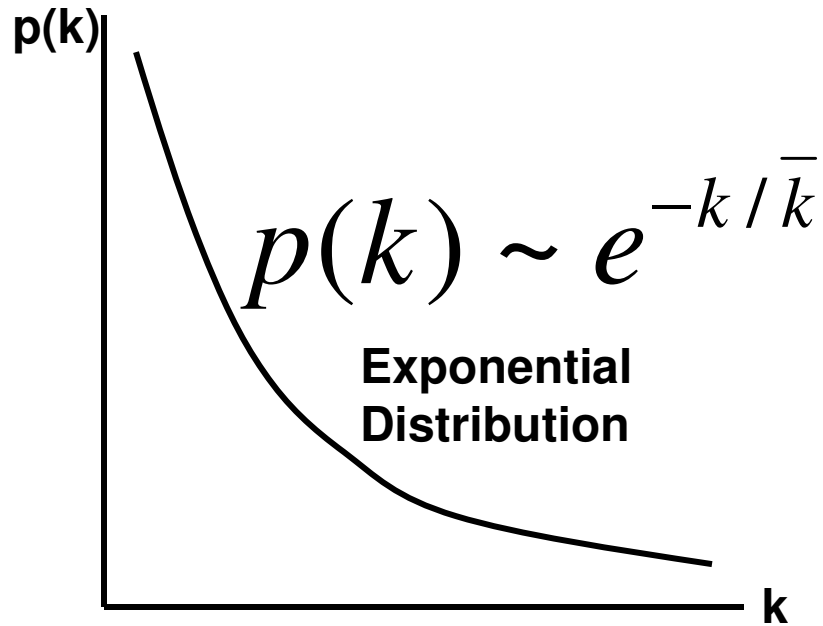
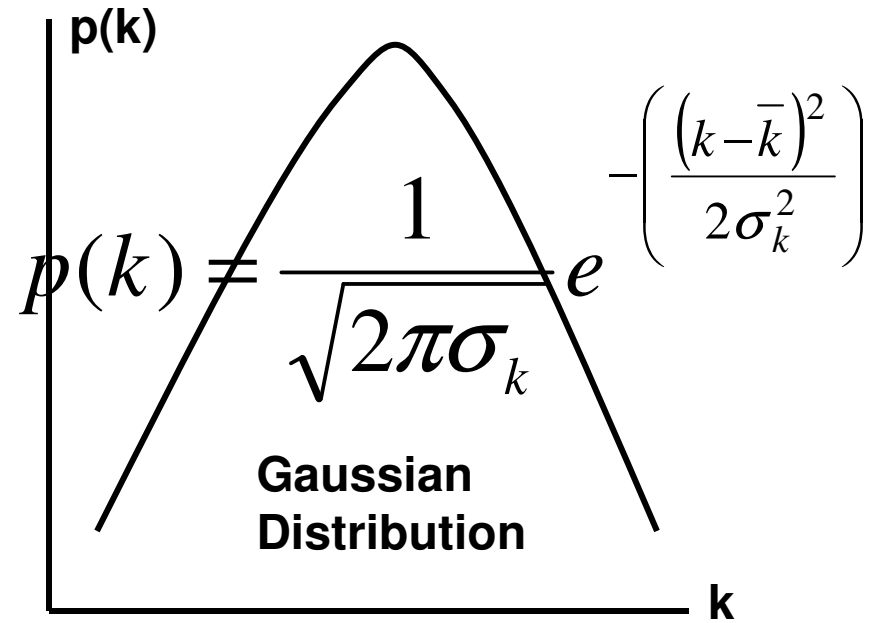
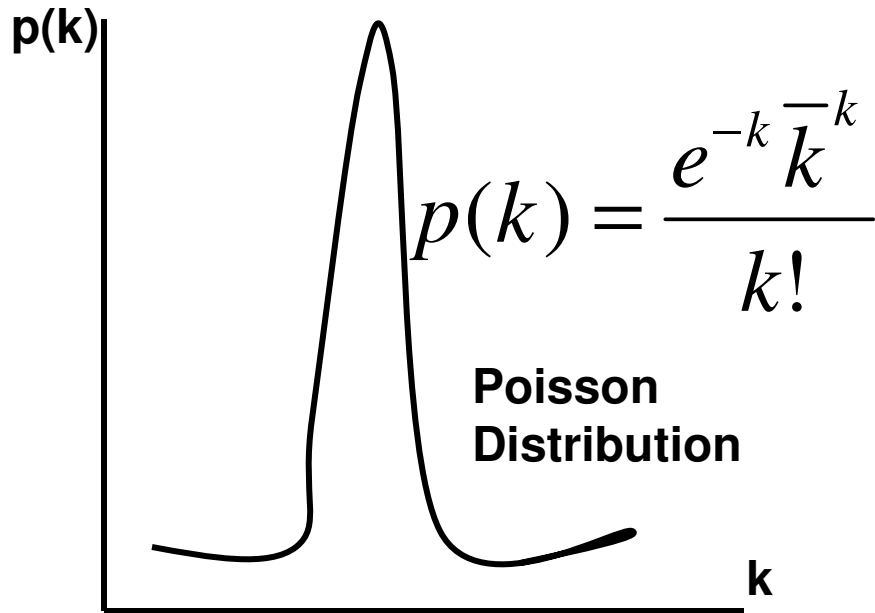

Power-Law Degree Distribution

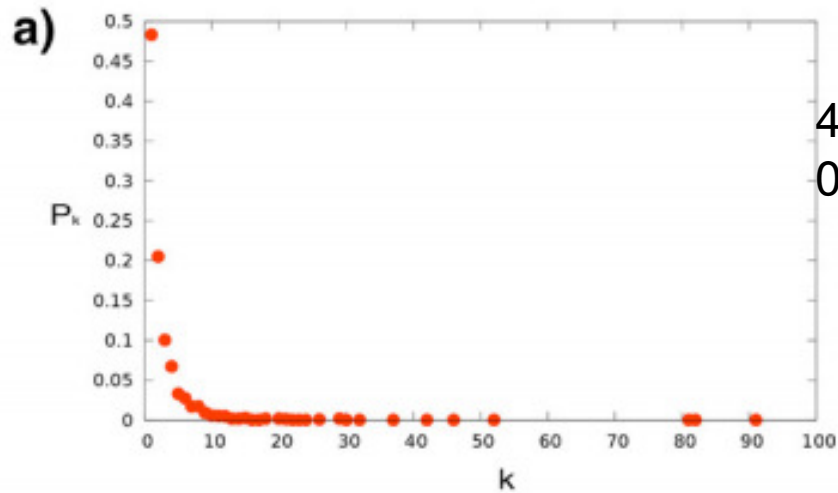

48% (0.48) of the nodes have degree 1
0.0005 of the nodes have degree 92.

Source:
Figure 2.4b: Barabasi

b)

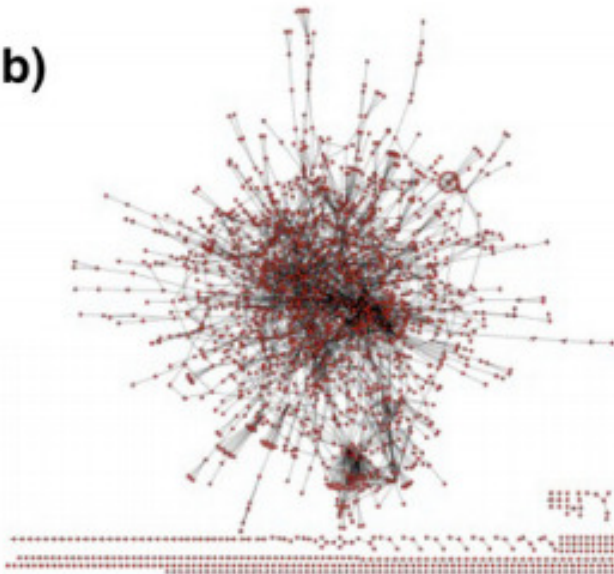

c)

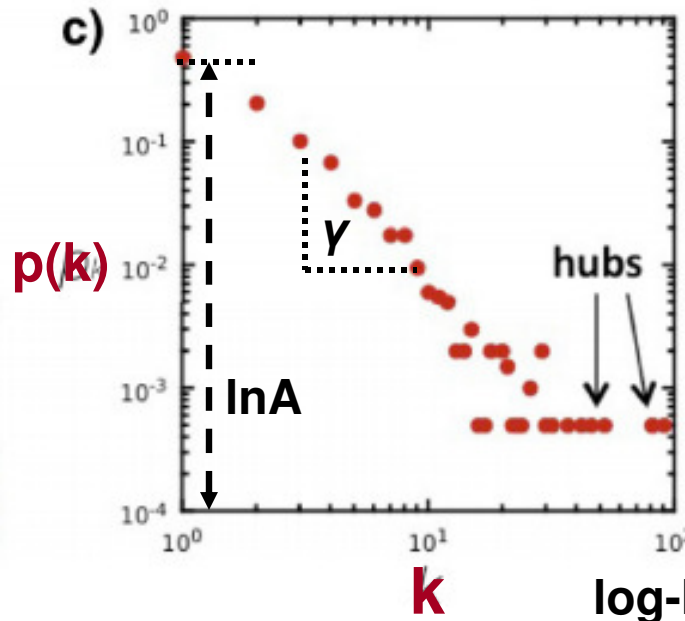

$$p(k) = Ak^{-\gamma}$$
$$\ln(p(k)) = -\gamma \ln k + \ln A$$

Slope = $-\gamma$
Y-Intercept = $\ln A$

Adjacency Matrix

- Unweighted graphs: $A_{ij} = 1$ if there is a link pointing from node i to node j , and 0 otherwise
- Weighted graphs: $A_{ij} = w_{ij}$ – weight of a link from node i to node j , and 0 otherwise

$$A_{ij} = \begin{pmatrix} A_{11} & A_{12} & A_{13} & A_{14} \\ A_{21} & A_{22} & A_{23} & A_{24} \\ A_{31} & A_{32} & A_{33} & A_{34} \\ A_{41} & A_{42} & A_{43} & A_{44} \end{pmatrix}$$

Assortativity Index

- Assortativity is a measure of the association of nodes of similar degrees. That is, high degree nodes tend to associate with high degree nodes and low-degree nodes with low-degree nodes.
- On the other hand, if high degree nodes associate with low degree nodes and vice-versa, it is referred to as disassortativity.
- We measure the assortativity index as the Pearson Correlation Coefficient (r) evaluated on the degrees of the end nodes of every link in the network.
 - Positive values of r indicate the network exhibits assortativity.
 - Negative values of r indicate the network exhibits disassortativity.
 - Values of r close to 0 indicates the network is more neutral.

$$r = \frac{\sum_{i=1}^n (X_i - \bar{X})(Y_i - \bar{Y})}{\sqrt{\sum_{i=1}^n (X_i - \bar{X})^2} \sqrt{\sum_{i=1}^n (Y_i - \bar{Y})^2}}$$

Example: Assortativity Index

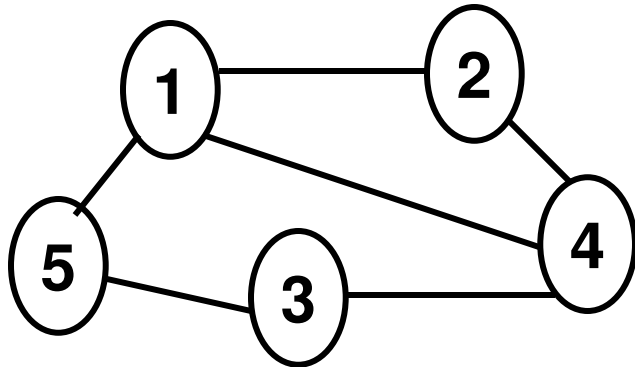

$$r = \frac{\sum_{i=1}^n (X_i - \bar{X})(Y_i - \bar{Y})}{\sqrt{\sum_{i=1}^n (X_i - \bar{X})^2} \sqrt{\sum_{i=1}^n (Y_i - \bar{Y})^2}}$$

We follow the convention of considering edges in the increasing order of the left node ID, followed by increasing order of right node ID.

Edges	Degrees of End Nodes		X - Avg(X)	Y - Avg(Y)	(X-Avg(X))(Y-Avg(Y))	
	Degree(X)	Degree(Y)				
1 - 2	3	2	0.5	-0.5	-0.25	
1 - 4	3	3	0.5	0.5	0.25	
1 - 5	3	2	0.5	-0.5	-0.25	
2 - 4	2	3	-0.5	0.5	-0.25	
3 - 4	2	3	-0.5	0.5	-0.25	
3 - 5	2	2	-0.5	-0.5	0.25	
Avg. X	2.5	2.5	SumSq	1.5	1.5	Sum -0.5

Assortativity Index = $-0.5 / [\text{sqrt}(1.5) * \text{sqrt}(1.5)] = -0.333$ [disassortativity]

Assortativity of Social Networks

<u>Network</u>	<u># Nodes</u>	<u>Assortativity Index</u>
Physics		
Co-authorship	52,909	0.363
Film actor		
Collaborations	449,913	0.208
Company		
Directors	7,673	0.276
E-mail Address		
Books	16,881	0.092

In real world, most of the social networks are assortative and the non-social Networks are typically disassortative. However, there are some exceptions.

<u>Network</u>	<u>Assortativity Index</u>	<u>Network</u>	<u>Assortativity Index</u>
Drug Users	-0.118	Roget's Thesaurus	0.174
Karate Club	-0.476	Protein Structure	0.412
Students dating	-0.119	St Marks Food Web	0.118

Clumping Index

- The clumping index is a measure of the occurrence of the nodes together as a clump (cluster) - compactly or spread out. The parameter α is typically chosen as 2.

$$\Lambda(G, k, \alpha) = \sum_{i>j}^{n(n-1)/2} \frac{k_i k_j}{(d_{ij})^\alpha}$$

(for undirected network)

Clumping Index of a complete Graph of n nodes
= $n(n-1)^3/2$

$$\Lambda(G, k, \alpha) = \sum_{i \neq j}^{n(n-1)} \frac{k_i k_j}{(d_{ij})^\alpha}$$

(for directed network)

The Clumping Index increases with increase in node degree; but, decreases with increase in the distance between the nodes. The Clumping Index will be high when we have high degree nodes that are compactly placed together.

Note that $\Lambda(G - e) \leq \Lambda(G)$.

Complete graphs have the highest Λ as distances are all 1s and the nodes have the highest degree.

Clumping Index has nothing to do with assortativity or disassortativity.

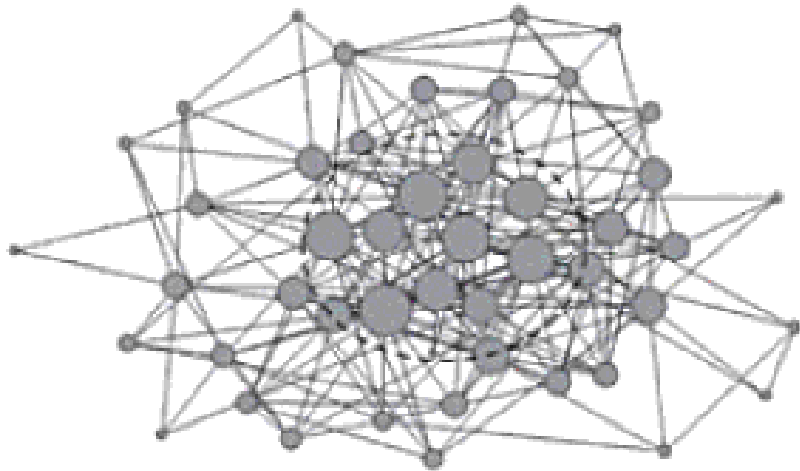

Assortativity Index = 0.118
High Clumping

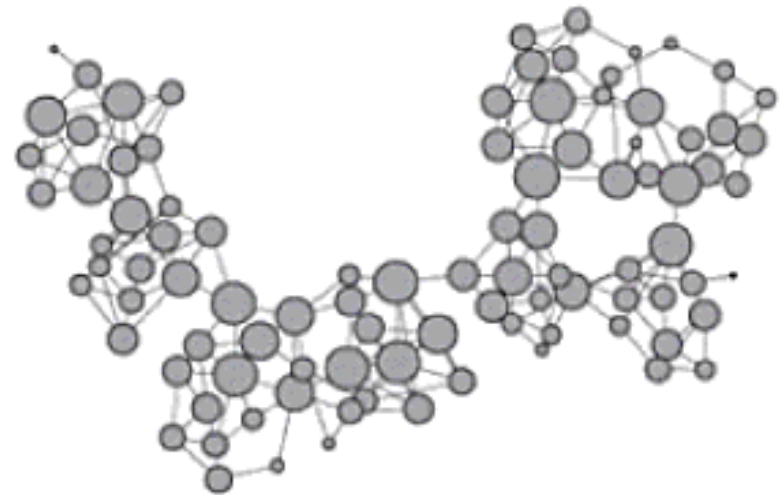

Assortativity Index = 0.129
Low Clumping

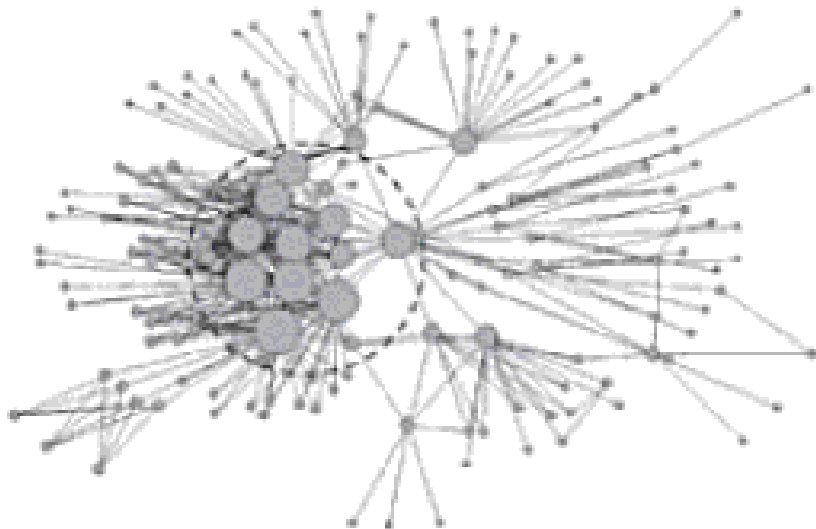

Assortativity Index = -0.304
High Clumping

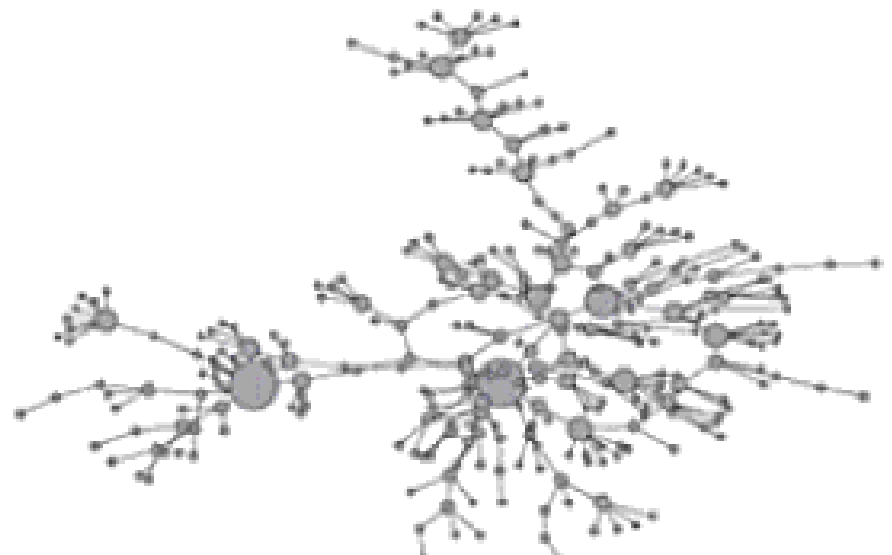

Assortativity Index = -0.227
Low Clumping

Clumping Index Examples 1 and 2

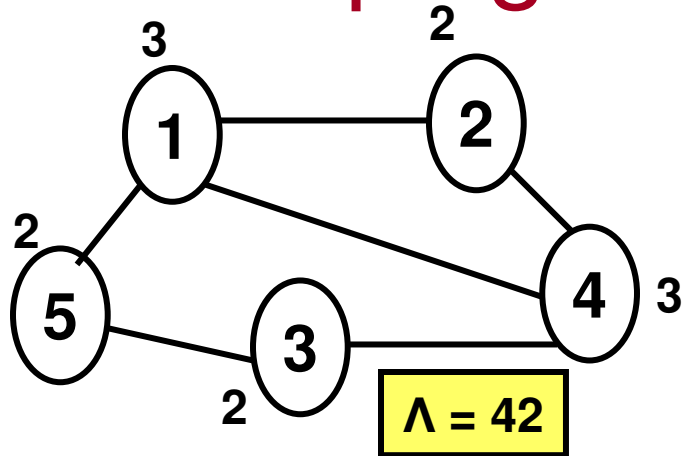

Node Pair	Degree Product (a)	Distance d_{ij}	Distance d_{ij}^2 (b)	(a) --- (b)
1-2	6	1	1	6
1-3	6	2	4	1.5
1-4	9	1	1	9
1-5	6	1	1	6
2-3	4	2	4	1
2-4	6	1	1	6
2-5	4	2	4	1
3-4	6	1	1	6
3-5	4	1	1	4
4-5	6	2	4	1.5

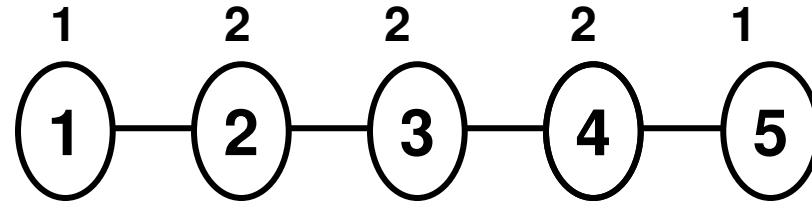

Node Pair	Degree Product (a)	Distance d_{ij}	Distance d_{ij}^2 (b)	(a) --- (b)
1-2	2	1	1	2
1-3	2	2	4	0.5
1-4	2	3	9	0.22
1-5	1	4	16	0.063
2-3	4	1	1	4
2-4	4	2	4	1
2-5	2	3	9	0.22
3-4	4	1	1	4
3-5	2	2	4	0.5
4-5	2	1	1	2

Λ = 14.5

Clumping Index Example 3

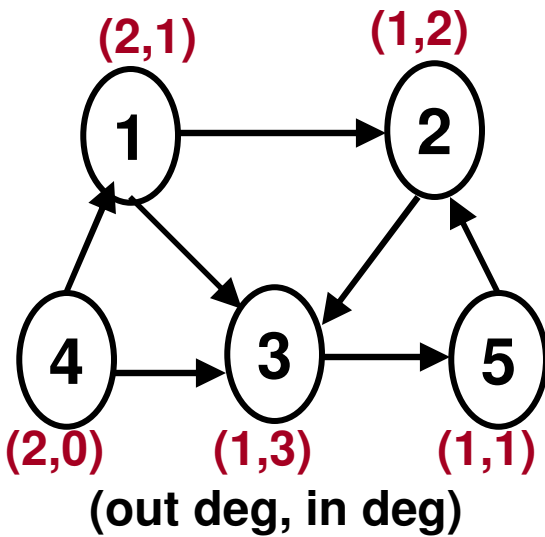

Clumping Index = 27.19

Node Pair	Out deg	In deg	Degree Product (a)	Distance d_{ij}	d_{ij}^2 (b)	(a) --- (b)
1->2	2	2	4	1	1	4
1->3	2	3	6	1	1	6
1->4	2	0	0	∞	∞	N/A
1->5	2	1	2	2	4	0.5
2->1	1	1	1	∞	∞	0
2->3	1	3	3	1	1	3
2->4	1	0	0	∞	∞	N/A
2->5	1	1	1	2	4	0.5
3->1	1	1	1	∞	∞	0
3->2	1	2	2	2	4	0.5
3->4	1	0	0	∞	∞	N/A
3->5	1	1	1	1	1	1.0
4->1	2	1	2	1	1	2.0
4->2	2	2	4	3	9	0.44
4->3	2	3	6	1	1	6.0
4->5	2	1	2	2	4	0.5
5->1	1	1	1	∞	∞	0.0
5->2	1	2	2	1	1	2.0
5->3	1	3	3	2	4	0.75
5->4	1	0	0	∞	∞	N/A

Eigenvalue and Eigenvector

- Let A be an $n \times n$ matrix.
- A scalar λ is called an Eigenvalue of A if there is a non-zero vector X such that $AX = \lambda X$. Such a vector X is called an Eigenvector of A corresponding to λ .

- Example: $\begin{bmatrix} 2 \\ 1 \end{bmatrix}$ is an Eigenvector of $A = \begin{bmatrix} 3 & 2 \\ 3 & -2 \end{bmatrix}$ for $\lambda = 4$

$$\begin{aligned} \begin{pmatrix} 3 & 2 \\ 3 & -2 \end{pmatrix} \begin{pmatrix} 2 \\ 1 \end{pmatrix} &\stackrel{?}{=} 4 \begin{pmatrix} 2 \\ 1 \end{pmatrix} \\ \begin{pmatrix} 3 \cdot 2 + 2 \cdot 1 \\ 3 \cdot 2 + (-2) \cdot 1 \end{pmatrix} &\stackrel{?}{=} \begin{pmatrix} 8 \\ 4 \end{pmatrix} \\ \begin{pmatrix} 8 \\ 4 \end{pmatrix} &\stackrel{\checkmark}{=} \begin{pmatrix} 8 \\ 4 \end{pmatrix} \end{aligned}$$

Finding Eigenvalues and Eigenvectors

$$A = \begin{bmatrix} 7 & 3 \\ 3 & -1 \end{bmatrix}$$

$$\textcircled{1} \lambda I = \lambda \begin{bmatrix} 1 & 0 \\ 0 & 1 \end{bmatrix} = \begin{bmatrix} \lambda & 0 \\ 0 & \lambda \end{bmatrix}$$

$$\textcircled{2} A - \lambda I = \begin{bmatrix} 7 & 3 \\ 3 & -1 \end{bmatrix} - \begin{bmatrix} \lambda & 0 \\ 0 & \lambda \end{bmatrix} \\ = \begin{bmatrix} 7-\lambda & 3 \\ 3 & -1-\lambda \end{bmatrix}$$

$$\textcircled{3} \det \begin{bmatrix} 7-\lambda & 3 \\ 3 & -1-\lambda \end{bmatrix} \\ = (7-\lambda)(-1-\lambda) - (3)(3) \\ = -7 - 7\lambda + \lambda + \lambda^2 - 9 \\ = \lambda^2 - 6\lambda - 16$$

(4) Solving for λ :

$$(\lambda - 8)(\lambda + 2) = 0$$

$\lambda = 8$ and $\lambda = -2$ are the Eigen values

(5) Consider $A - \lambda I$

$$\textcircled{4} \begin{bmatrix} 7-\lambda & 3 \\ 3 & -1-\lambda \end{bmatrix}$$

$\lambda = 8$:

$$\begin{bmatrix} 7-8 & 3 \\ 3 & -1-8 \end{bmatrix} = \begin{bmatrix} -1 & 3 \\ 3 & -9 \end{bmatrix} = B$$

Solve $B X = 0$

$$\begin{bmatrix} -1 & 3 \\ 3 & -9 \end{bmatrix} \begin{bmatrix} X_1 \\ X_2 \end{bmatrix} = \begin{bmatrix} 0 \\ 0 \end{bmatrix}$$

$$-X_1 + 3X_2 = 0 \rightarrow X_1 = 3X_2$$

$$3X_1 - 9X_2 = 0 \rightarrow 3X_1 = 9X_2 \rightarrow X_1 = 3X_2$$

If $X_2 = 1$;
 $X_1 = 3$ $\begin{bmatrix} 3 \\ 1 \end{bmatrix}$ is an eigenvector
for $\lambda = 8$

Finding Eigenvalues and Eigenvectors

For $\lambda = -2$

$$\begin{bmatrix} 7 - (-2) & 3 \\ 3 & -1 - (-2) \end{bmatrix} = \begin{bmatrix} 9 & 3 \\ 3 & 1 \end{bmatrix}$$

Solve $B X = 0$

$$\begin{bmatrix} 9 & 3 \\ 3 & 1 \end{bmatrix} \begin{bmatrix} X_1 \\ X_2 \end{bmatrix} = \begin{bmatrix} 0 \\ 0 \end{bmatrix}$$

$$9X_1 + 3X_2 = 0 \rightarrow X_2 = -3X_1$$

$$3X_1 + X_2 = 0 \rightarrow X_2 = -3X_1$$

If $X_1 = 1$;
 $X_2 = -3$ $\begin{bmatrix} 1 \\ -3 \end{bmatrix}$ is an eigenvector
for $\lambda = -2$

Verification

$$A = \begin{bmatrix} 7 & 3 \\ 3 & -1 \end{bmatrix}$$

$$AX = \lambda X$$

For $\lambda = 8$ and $X = \begin{bmatrix} 3 \\ 1 \end{bmatrix}$

$$\begin{bmatrix} 7 & 3 \\ 3 & -1 \end{bmatrix} \begin{bmatrix} 3 \\ 1 \end{bmatrix} = \begin{bmatrix} 24 \\ 8 \end{bmatrix} = 8 \begin{bmatrix} 3 \\ 1 \end{bmatrix}$$

Spectral Radius (Network Index)

- The index of the network or the spectral radius of the node adjacency matrix A is the largest Eigenvalue of A , denoted $\lambda_1(A)$.
- The largest Eigen value of a connected undirected network is a unique positive value whose corresponding Eigenvector is the principal Eigenvector of the network.
- If k_{\min} , k_{avg} , k_{\max} are the minimum, average and maximum node degrees, then:

$$k_{\min} \leq k_{\text{avg}} \leq \lambda_1(A) \leq k_{\max}$$

Use this website to determine Eigenvalues and Eigenvectors for a matrix. http://www.arndt-bruenner.de/mathe/scripts/engl_eigenwert.htm

The largest Eigenvalue is 2.4811.

$$k_{\min} = 2; k_{\max} = 3; k_{\text{avg}} = 2.4$$
$$2 < 2.4 < 2.4811 < 3$$

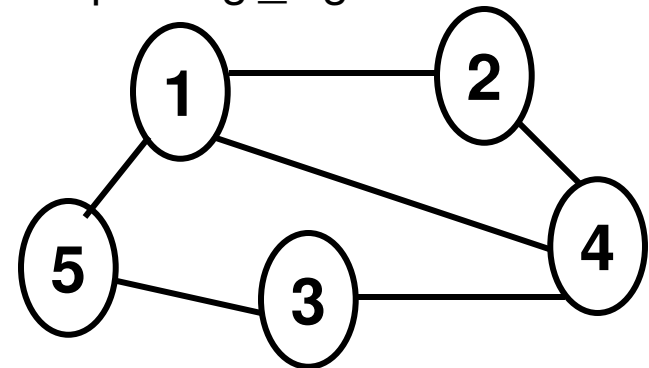

Cocitation and Bibliographic Coupling

- The CB-Adjacency matrix is the one where there is a 1 in (row index i , column index j) if there is an edge $j \rightarrow i$.
 - $A_{ij} = 1$ iff there is an edge $j \rightarrow i$
 - $A_{ij} = 0$ iff there is NO edge from j to i .
- Cocitation and Bibliographic coupling are some of the techniques to transform a directed graph to an undirected graph and analyze the info hidden in the directed graph.
- The **cocitation of two vertices** i and j in a directed graph is the number of vertices k that have outgoing edges pointing to both i and j .
 - Cocitation $C_{ij} = 1$ iff $A_{ik} = 1$ and $A_{jk} = 1$.

$$C_{ij} = \sum_{k=1}^n A_{ik} A_{jk} = \sum_{k=1}^n A_{ik} A_{kj}^T$$

$$C = AA^T$$

$$C_{ij} = 3$$

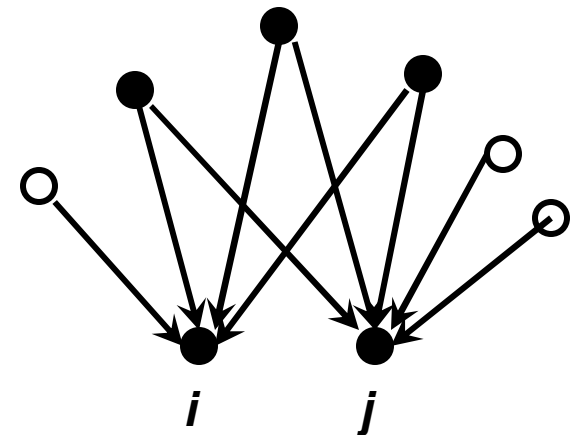

Cocitation Coupling: Example

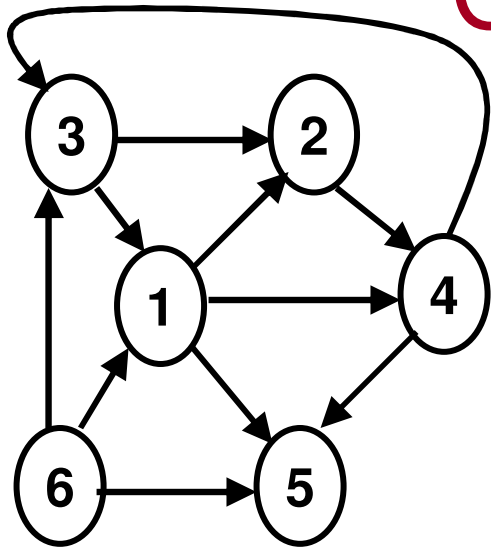

CB Adj. Matrix $A =$

$$\begin{pmatrix}
 1 & 2 & 3 & 4 & 5 & 6 \\
 1 & 0 & 0 & 1 & 0 & 0 & 1 \\
 2 & 1 & 0 & 1 & 0 & 0 & 0 \\
 3 & 0 & 0 & 0 & 1 & 0 & 1 \\
 4 & 1 & 1 & 0 & 0 & 0 & 0 \\
 5 & 1 & 0 & 0 & 1 & 0 & 1 \\
 6 & 0 & 0 & 0 & 0 & 0 & 0
 \end{pmatrix}$$

$A^T =$

$$\begin{pmatrix}
 1 & 2 & 3 & 4 & 5 & 6 \\
 1 & 0 & 1 & 0 & 1 & 1 & 0 \\
 2 & 0 & 0 & 0 & 1 & 0 & 0 \\
 3 & 1 & 1 & 0 & 0 & 0 & 0 \\
 4 & 0 & 0 & 1 & 0 & 1 & 0 \\
 5 & 0 & 0 & 0 & 0 & 0 & 0 \\
 6 & 1 & 0 & 1 & 0 & 1 & 0
 \end{pmatrix}$$

Cocitation Coupling Matrix =

$$\begin{pmatrix}
 1 & 2 & 3 & 4 & 5 & 6 \\
 1 & 0 & 0 & 1 & 0 & 0 & 1 \\
 2 & 1 & 0 & 1 & 0 & 0 & 0 \\
 3 & 0 & 0 & 0 & 1 & 0 & 1 \\
 4 & 1 & 1 & 0 & 0 & 0 & 0 \\
 5 & 1 & 0 & 0 & 1 & 0 & 1 \\
 6 & 0 & 0 & 0 & 0 & 0 & 0
 \end{pmatrix}
 \begin{pmatrix}
 1 & 2 & 3 & 4 & 5 & 6 \\
 1 & 0 & 1 & 0 & 1 & 1 & 0 \\
 2 & 0 & 0 & 0 & 1 & 0 & 0 \\
 3 & 1 & 1 & 0 & 0 & 0 & 0 \\
 4 & 0 & 0 & 1 & 0 & 1 & 0 \\
 5 & 0 & 0 & 0 & 0 & 0 & 0 \\
 6 & 1 & 0 & 1 & 0 & 1 & 0
 \end{pmatrix}
 =
 \begin{pmatrix}
 1 & 2 & 3 & 4 & 5 & 6 \\
 1 & 2 & 1 & 1 & 0 & 1 & 0 \\
 2 & 1 & 2 & 0 & 1 & 1 & 0 \\
 3 & 1 & 0 & 2 & 0 & 2 & 0 \\
 4 & 0 & 1 & 0 & 2 & 1 & 0 \\
 5 & 1 & 1 & 2 & 1 & 3 & 0 \\
 6 & 0 & 0 & 0 & 0 & 0 & 0
 \end{pmatrix}$$

Other than the entries for a vertex to itself, the only entries where $C_{ij} > 1$ are: $C_{35} = C_{53} = 2$; meaning that two papers (4 and 6) are citing both papers 3 and 5.

Cocitation Coupling

- A cocitation network comprises of only undirected edges (i, j) , iff $C_{ij} > 0$.
- The value of C_{ij} is a good indicator of two papers i and j that deal with related topics.
 - If two papers are often cited together in the same bibliography, they probably have something in common.
 - The more often they are cited together, the more likely it is that they are related.
- **Strength:** Cocitation counts of papers increase with time. The rate of increase can be used to trace the evolution of an academic field.
- The co-citation measure reflects the opinion of many authors.
- **Weakness with Cocitation coupling:** The relative similarity between two papers is being adjudged with the number of papers citing them.
- For two papers i and j to be adjudged to be “strongly related” to each other, we should have more incoming edges to both of them.
 - This may not be the case for two papers (or at least one of them) that have few citations.
 - Also, the relative similarity of two papers cannot be computed until both the papers are cited by at least one paper.

Bibliographic Coupling

- Two papers i and j are related if they refer to one or more papers k in common.
 - The number of common references is an indicator of the similarity between the two papers.
 - However, the similarity is based on the opinion of only the authors of the two papers; not others in the subject area – a weakness to assess similarity between two papers.
 - It is a static measure: established when a paper gets published and not updated henceforth.
 - Hence, it cannot be used to trace the evolution of an academic field.
 - Strength: Unlike Co-citation coupling, there is no need to wait for other papers to cite.

Bibliographic Coupling

- The **bibliographic coupling** **of two vertices** i and j in a directed graph is the number of vertices k that have incoming edges from both i and j .
 - Bibliographic coupling $B_{ij} = 1$ iff $A_{ki} = 1$ and $A_{kj} = 1$.

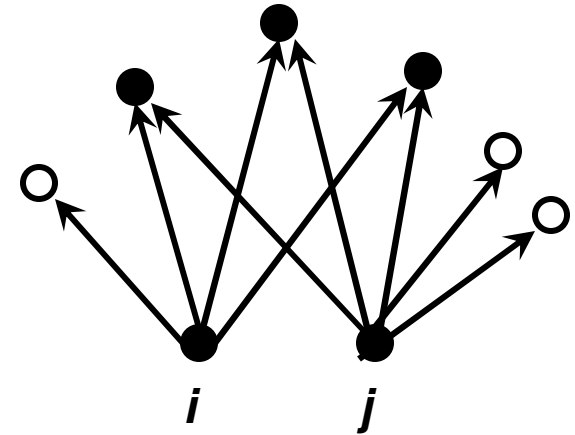

$$B_{ij} = \sum_{k=1}^n A_{ki} A_{kj} = \sum_{k=1}^n A_{ik}^T A_{kj}$$

$$B = A^T A$$

Bibliographic Coupling: Example

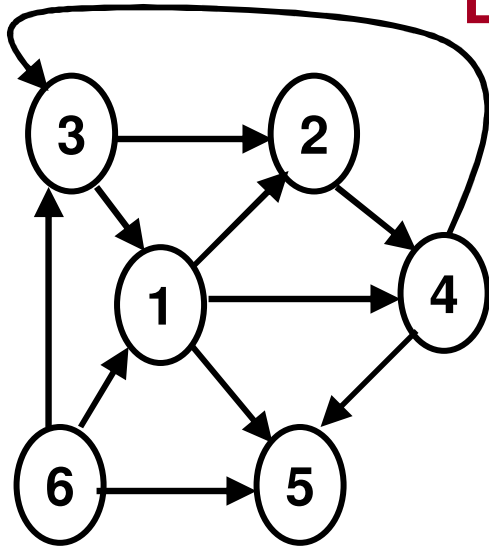

CB Adj. Matrix $A =$

$$\begin{pmatrix}
 1 & 2 & 3 & 4 & 5 & 6 \\
 1 & 0 & 0 & 1 & 0 & 0 & 1 \\
 2 & 1 & 0 & 1 & 0 & 0 & 0 \\
 3 & 0 & 0 & 0 & 1 & 0 & 1 \\
 4 & 1 & 1 & 0 & 0 & 0 & 0 \\
 5 & 1 & 0 & 0 & 1 & 0 & 1 \\
 6 & 0 & 0 & 0 & 0 & 0 & 0
 \end{pmatrix}$$

$$A^T =
 \begin{pmatrix}
 1 & 2 & 3 & 4 & 5 & 6 \\
 1 & 0 & 1 & 0 & 1 & 1 & 0 \\
 2 & 0 & 0 & 0 & 1 & 0 & 0 \\
 3 & 1 & 1 & 0 & 0 & 0 & 0 \\
 4 & 0 & 0 & 1 & 0 & 1 & 0 \\
 5 & 0 & 0 & 0 & 0 & 0 & 0 \\
 6 & 1 & 0 & 1 & 0 & 1 & 0
 \end{pmatrix}$$

Bibliogr. Coupling Matrix =

$$\begin{pmatrix}
 1 & 2 & 3 & 4 & 5 & 6 \\
 1 & 0 & 1 & 0 & 1 & 1 & 0 \\
 2 & 0 & 0 & 0 & 1 & 0 & 0 \\
 3 & 1 & 1 & 0 & 0 & 0 & 0 \\
 4 & 0 & 0 & 1 & 0 & 1 & 0 \\
 5 & 0 & 0 & 0 & 0 & 0 & 0 \\
 6 & 1 & 0 & 1 & 0 & 1 & 0
 \end{pmatrix}
 \begin{pmatrix}
 1 & 2 & 3 & 4 & 5 & 6 \\
 1 & 0 & 0 & 1 & 0 & 0 & 1 \\
 2 & 1 & 0 & 1 & 0 & 0 & 0 \\
 3 & 0 & 0 & 0 & 1 & 0 & 1 \\
 4 & 1 & 1 & 0 & 0 & 0 & 0 \\
 5 & 1 & 0 & 0 & 1 & 0 & 1 \\
 6 & 0 & 0 & 0 & 0 & 0 & 0
 \end{pmatrix}
 =
 \begin{pmatrix}
 1 & 2 & 3 & 4 & 5 & 6 \\
 1 & 3 & 1 & 1 & 1 & 0 & 1 \\
 2 & 1 & 1 & 0 & 0 & 0 & 0 \\
 3 & 1 & 0 & 2 & 0 & 0 & 1 \\
 4 & 1 & 0 & 0 & 2 & 0 & 2 \\
 5 & 0 & 0 & 0 & 0 & 0 & 0 \\
 6 & 1 & 0 & 1 & 2 & 0 & 3
 \end{pmatrix}$$

Other than the entries for a vertex to itself, the only entries where $B_{ij} > 1$ are: $B_{46} = B_{64} = 2$; meaning that two papers (1 and 3) are both being referred by papers 4 and 6.

Bipartite Graph and Projection

- A bipartite graph (or bigraph) is a network whose nodes are divided into two disjoint sets U and V ; the only links in the graph are those connecting a U -node to a V -node.
 - There is no link connecting two U -nodes or two V -nodes.
 - The U -nodes can be of one color and the V -nodes can be of another color; a link always connects two nodes of different colors.
- Projection:
 - Projection U : Links involving the U -nodes. Two U -nodes are connected if they link to the same V -node in the bipartite graph.
 - Projection V : Links involving the V -nodes. Two V -nodes are connected if they link to the same U -node in the bipartite graph.

Bipartite Graph and Projection

Projection U
(Vertex Projection)

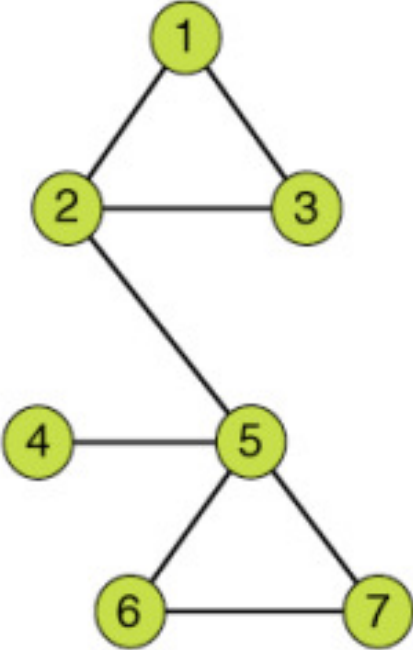

U V

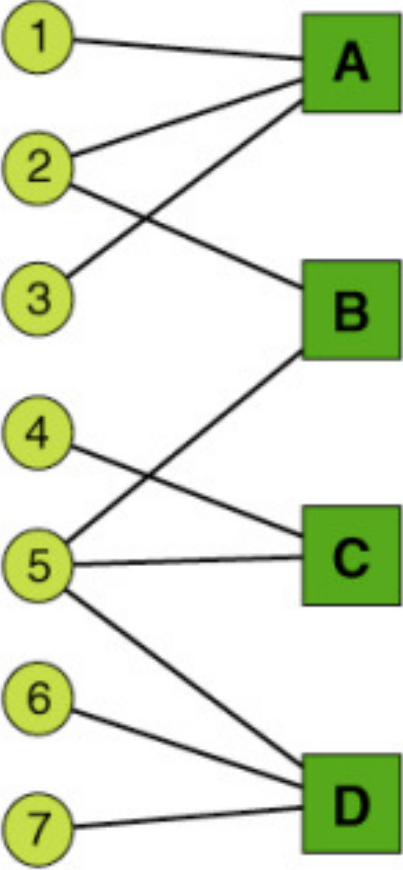

Projection V
(Group Projection)

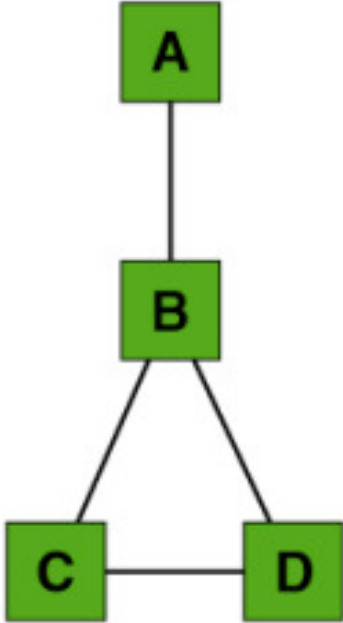

Source: Fig. 2.9a, Barabasi

Incidence Matrix and Projections

Vertex Projection

Two vertices are connected if they belong to at least one common group.

$$VP_{ij} = \sum_{k=1}^g B_{ki} B_{kj}$$

$$VP_{ij} = \sum_{k=1}^g B_{ik}^T B_{kj}$$

$$VP = B^T B$$

VP_{ij} is the number of groups that i and j share.

VP_{ii} is the number of groups to which i belongs to.

Group Projection

Two groups are connected if they share at least one common vertex.

$$GP_{ij} = \sum_{k=1}^n B_{ik} B_{jk}$$

$$GP_{ij} = \sum_{k=1}^n B_{ik} B_{kj}^T$$

$$GP = B B^T$$

GP_{ij} is the number of vertices that groups i and j share.

GP_{ii} is the number of vertices that belong to group i .

Groups

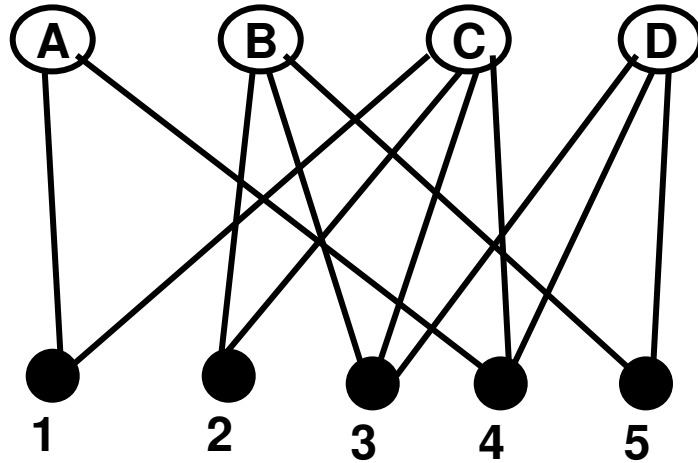

	1	2	3	4	5
A	1	0	0	1	0
B	0	1	1	0	1
C	1	1	1	1	0
D	0	0	1	1	1

Vertices

Adjacency Matrix **B**

$$\begin{matrix}
 \begin{matrix} 1 & 0 & 0 & 1 & 0 \\ 0 & 1 & 1 & 0 & 1 \\ 1 & 1 & 1 & 1 & 0 \\ 0 & 0 & 1 & 1 & 1 \end{matrix} &
 \begin{matrix} 1 & 0 & 1 & 0 \\ 0 & 1 & 1 & 0 \\ 0 & 1 & 1 & 1 \\ 1 & 0 & 1 & 1 \\ 0 & 1 & 0 & 1 \end{matrix} &
 = &
 \begin{matrix} \text{A} & \text{B} & \text{C} & \text{D} \\ \text{A} & 2 & 0 & 2 & 1 \\ \text{B} & 0 & 3 & 2 & 2 \\ \text{C} & 2 & 2 & 4 & 2 \\ \text{D} & 1 & 2 & 2 & 3 \end{matrix}
 \end{matrix}$$

Group Projection: Indicates the number of vertices that are common to any two groups.

$$\begin{matrix}
 \begin{matrix} 1 & 0 & 1 & 0 \\ 0 & 1 & 1 & 0 \\ 0 & 1 & 1 & 1 \\ 1 & 0 & 1 & 1 \\ 0 & 1 & 0 & 1 \end{matrix} &
 \begin{matrix} 1 & 0 & 0 & 1 & 0 \\ 0 & 1 & 1 & 0 & 1 \\ 1 & 1 & 1 & 1 & 0 \\ 0 & 0 & 1 & 1 & 1 \end{matrix} &
 = &
 \begin{matrix} 1 & 2 & 1 & 1 & 2 & 0 \\ 2 & 1 & 2 & 2 & 1 & 1 \\ 3 & 1 & 2 & 3 & 2 & 2 \\ 4 & 2 & 1 & 2 & 3 & 1 \\ 5 & 0 & 1 & 2 & 1 & 2 \end{matrix}
 \end{matrix}$$

Vertex Projection: Indicates the number of common groups for any two vertices.

Examples of Bipartite Graphs and Projections

- Actor-movie network: Actors are one set of nodes and the movies are another set of nodes. Each actor is connected to the movie(s) in which s/he has acted.
 - Projection Actors (Actor network): Two actors are connected if they acted together in at least one movie
 - Projection Movies (Movie network): Two movies are connected if they had at least one common actor.
- Diseasome network: One set of nodes are the diseases and another set of nodes are the genes: A disease is connected to a gene if mutations in that gene are known to affect the particular disease.
 - Projection Gene (Gene network): Two genes are connected if they are associated with the same disease.
 - Projection Disease (Disease network): Two diseases are connected if the same genes are associated with them, indicating the two diseases have common genetic origins.

Paths and Distances in Networks

- A path between two nodes i and j is a route along the links of the network; the length (distance d_{ij}) is the number of links the path contains.
 - In an undirected network, $d_{ij} = d_{ji}$
 - In a directed network, d_{ij} need not be equal to d_{ji}
- Shortest path (geodesic path): between any two nodes i and j is the path with the fewest number of links.
- Diameter of a network: Maximum of the shortest path lengths between any two nodes
- The number of paths of length k between any two vertices can be found from: A^k where A is the adjacency matrix of the network.
- The shortest path length between any two nodes i and j is the minimum value of k for which $A^{k-1}[i, j] = 0$ and $A^k[i, j] > 0$.

Walks (Paths) of Certain Length

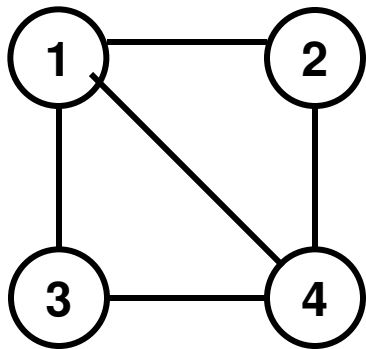

	1	2	3	4
1	0	1	1	1
2	1	0	0	1
3	1	0	0	1
4	1	1	1	0

A Walk is a path in which one or more vertices (other than the source and destination) are repeated.

$$\mathbf{A}^2 = \begin{matrix} & \begin{matrix} 1 & 2 & 3 & 4 \end{matrix} \\ \begin{matrix} 1 \\ 2 \\ 3 \\ 4 \end{matrix} & \begin{pmatrix} 0 & 1 & 1 & 1 \\ 1 & 0 & 0 & 1 \\ 1 & 0 & 0 & 1 \\ 1 & 1 & 1 & 0 \end{pmatrix} \end{matrix} = \begin{matrix} & \begin{matrix} 1 & 2 & 3 & 4 \end{matrix} \\ \begin{matrix} 1 \\ 2 \\ 3 \\ 4 \end{matrix} & \begin{pmatrix} 0 & 1 & 1 & 1 \\ 1 & 0 & 0 & 1 \\ 1 & 0 & 0 & 1 \\ 1 & 1 & 1 & 0 \end{pmatrix} \end{matrix} = \begin{matrix} & \begin{matrix} 1 & 2 & 3 & 4 \end{matrix} \\ \begin{matrix} 1 \\ 2 \\ 3 \\ 4 \end{matrix} & \begin{pmatrix} 3 & 1 & 1 & 2 \\ 1 & 2 & 2 & 1 \\ 1 & 2 & 2 & 1 \\ 2 & 1 & 1 & 3 \end{pmatrix} \end{matrix}$$

Number of Paths of Certain Length

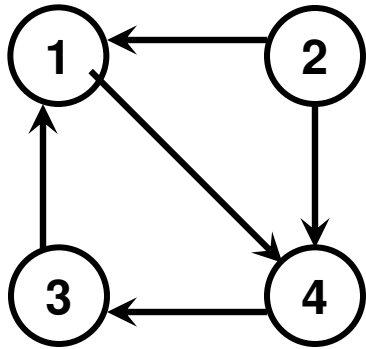

$$\begin{matrix}
 & \begin{matrix} 1 & 2 & 3 & 4 \end{matrix} \\
 \begin{matrix} 1 \\ 2 \\ 3 \\ 4 \end{matrix} & \begin{pmatrix} 0 & 0 & 0 & 1 \\ 1 & 0 & 0 & 1 \\ 1 & 0 & 0 & 0 \\ 0 & 0 & 1 & 0 \end{pmatrix}
 \end{matrix}$$

$$\mathbf{A}^2 = \begin{matrix} & \begin{matrix} 1 & 2 & 3 & 4 \end{matrix} \\ \begin{matrix} 1 \\ 2 \\ 3 \\ 4 \end{matrix} & \begin{pmatrix} 0 & 0 & 0 & 1 \\ 1 & 0 & 0 & 1 \\ 1 & 0 & 0 & 0 \\ 0 & 0 & 1 & 0 \end{pmatrix} \begin{matrix} \begin{matrix} 1 & 2 & 3 & 4 \\ 0 & 0 & 0 & 1 \\ 1 & 0 & 0 & 1 \\ 1 & 0 & 0 & 0 \\ 0 & 0 & 1 & 0 \end{matrix} \end{matrix} = \begin{matrix} & \begin{matrix} 1 & 2 & 3 & 4 \end{matrix} \\ \begin{matrix} 1 \\ 2 \\ 3 \\ 4 \end{matrix} & \begin{pmatrix} 0 & 0 & 1 & 0 \\ 0 & 0 & 1 & 1 \\ 0 & 0 & 0 & 1 \\ 1 & 0 & 0 & 0 \end{pmatrix}
 \end{matrix}$$

Path Terminologies

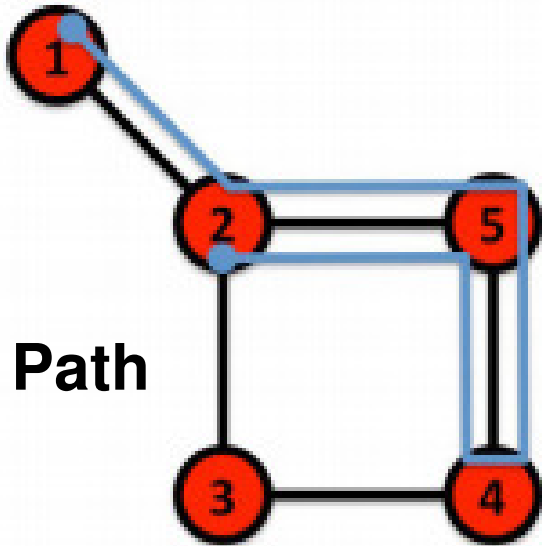

Path

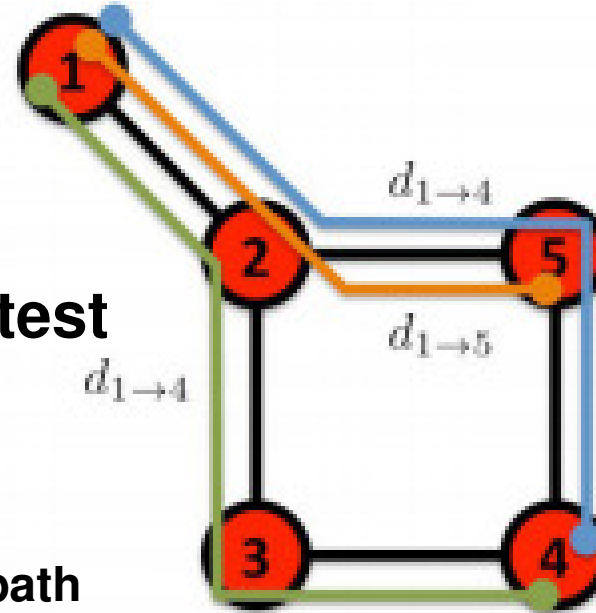

Shortest Path

Diameter: Largest shortest path

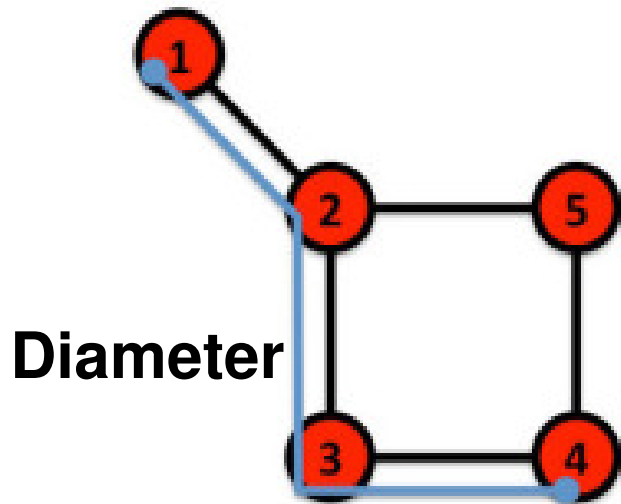

Diameter

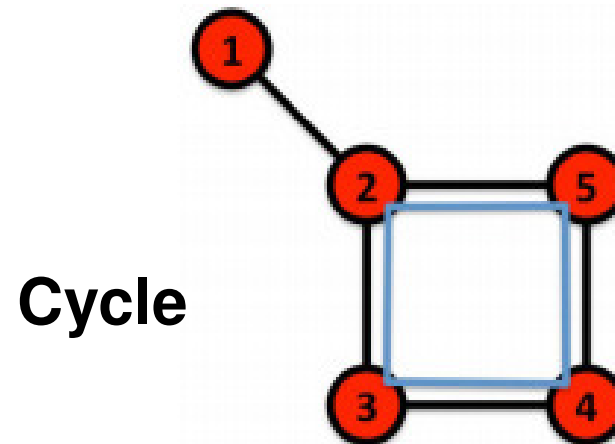

Cycle

Diameter

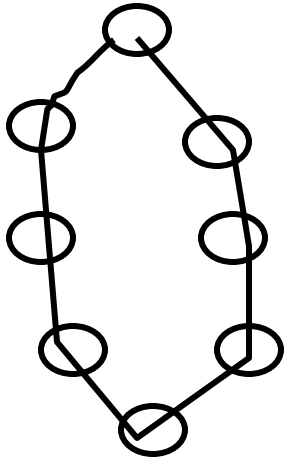

Diameter of a Ring = $N/2$ or $(N-1)/2$

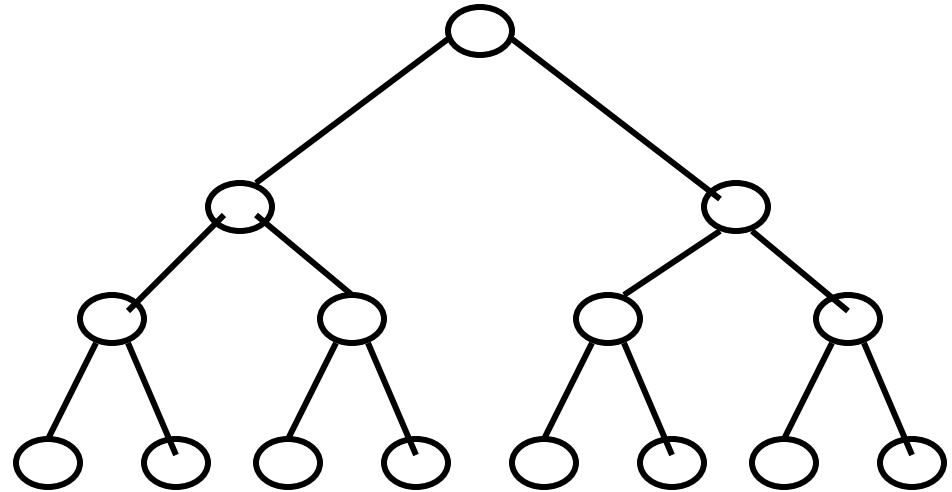

Diameter of a binary tree with K levels
nodes $N = 2^{(K+1)} - 1$
 $K+1 = \log_2(N+1)$

Diameter = $2K = 2 * [\log_2(N+1) - 1]$



Diameter of a Chain = $(N-1)$

Small Average Path Length and Diameter

- Milgram (1967) letter experiments
 - median 5 for the 25% that made it
- Co-Authorship studies
 - Grossman (2002) Math mean 7.6, max 27
 - Newman (2001) Physics mean 5.9, max 20
 - Goyal et al (2004) Economics mean 9.5, max 29
- WWW
 - Adamic, Pitkow (1999) – mean 3.1 (85.4% possible of 50M pages)
- Facebook
 - Backstrom et al (2012) – mean 4.74 (721 million users)\
- Small-World Property: If n is the number of nodes in the network, as n increases, the average path length of a random network is proportional to $\ln(n)$ and for a network with power-law degree distribution, the average path length is proportional to $\ln(n) / \ln(\ln(n))$.

Eccentricity, Diameter, Radius, Center

- The eccentricity of a node is the maximum of the shortest path distance (# hops) to any other node in the network.
- The diameter of the network is the maximum of the node eccentricity values.
- The radius of the network is the minimum of the node eccentricity values.
- A node is said to be central if its eccentricity is equal to the radius of the network.
- The set of nodes that are central constitute the center of the network.
- **Weiner Index:**

$$W(G) = \sum_{u=1}^n \sum_{v=1}^n dist(u,v)$$

Average Path Length:

$$\frac{W(G)}{n(n-1)}$$

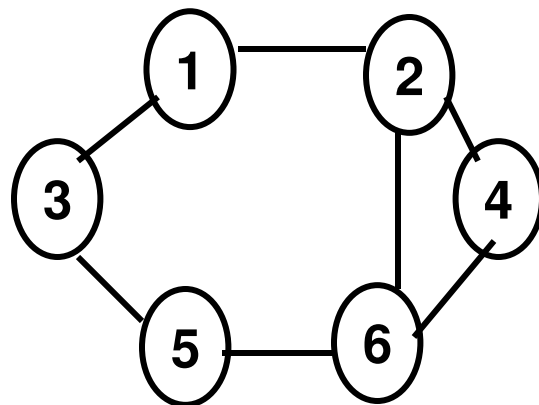

Nodes	Distances (Eccentricity)
1	1, 1, 2, 2, 2 (2)
2	1, 1, 1, 2, 2 (2)
3	1, 1, 2, 2, 3 (3)
4	1, 1, 2, 2, 3 (3)
5	1, 1, 2, 2, 2 (2)
6	1, 1, 1, 2, 2 (2)

Diameter = 3

Radius 2

Center = {1, 2, 5, 6}

Weiner Index = 48

Avg. Path Length = $48 / (6 \cdot 5)$
= 1.60

Components (Clusters)

- The vertices of a graph are said to be in a single component if there is a path between the vertices.
- A graph is said to be connected if all its vertices are in one single component; otherwise, the graph is said to be disconnected and consists of multiple components.
 - Adding one or more links (bridges) can connect the different components

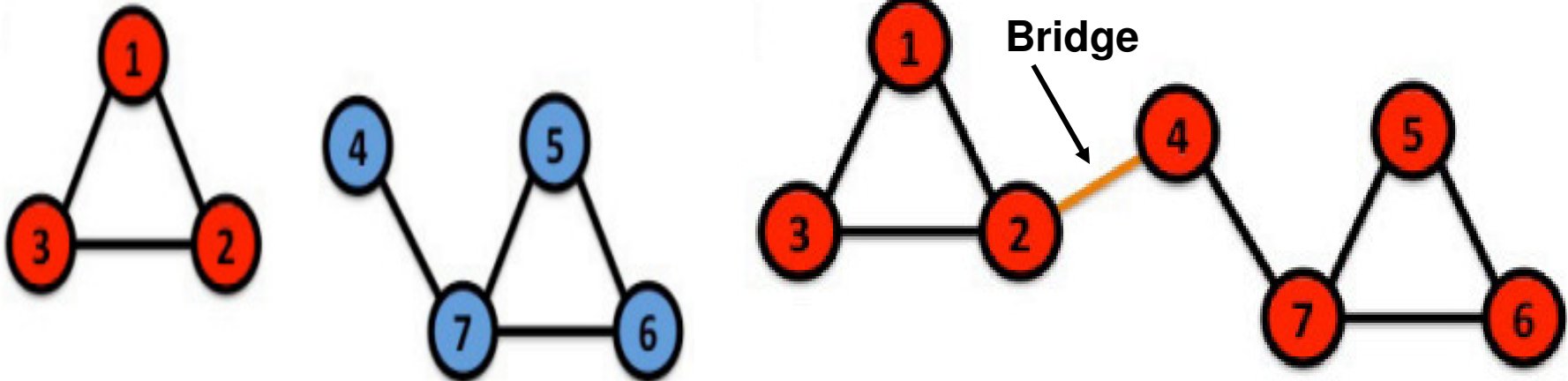

Laplacian Matrix

- Laplacian Matrix $L = D - A$

$$L_{ij} = \begin{cases} \text{deg}(i) & \text{for } i = j \\ -a_{ij} & \text{for } i \neq j \end{cases}$$

$$\begin{pmatrix} 3 & -1 & 0 & -1 & -1 \\ -1 & 3 & -1 & -1 & 0 \\ 0 & -1 & 2 & -1 & 0 \\ -1 & -1 & -1 & 4 & -1 \\ -1 & 0 & 0 & -1 & 2 \end{pmatrix}$$

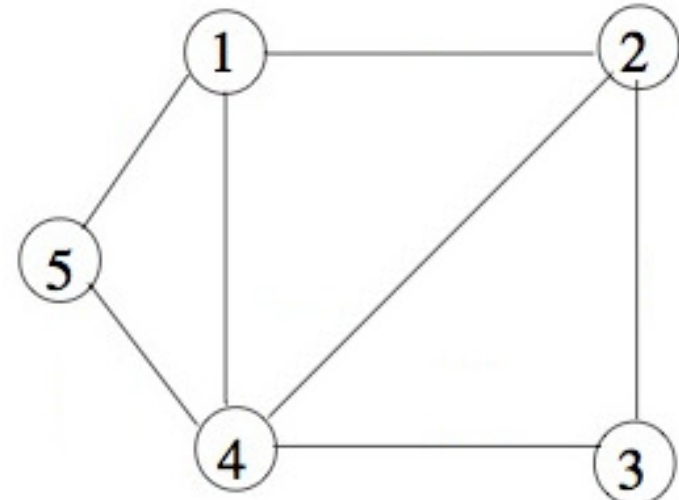

The n eigenvalues of an $n \times n$ Laplacian matrix are all positive.

The first eigenvalue is always 0.

The number of 0s among the Eigenvalues of the Laplacian Matrix indicates the number of Connected components of a graph.

The second smallest eigenvalue of the Laplacian matrix is a measure of the Connectivity of the graph and is called *Algebraic connectivity* (Fiedler Value).

The eigenvalues of the above Laplacian matrix are:

0 1.586 3.0 4.414 5.0

Max. Fiedler Value for a graph of n vertices is n (for a complete graph).

Laplacian Matrix

Components

Laplacian Matrix

Spanning Trees

If $\mu_1 = 0 < \mu_2 \leq \mu_3 \leq \dots \leq \mu_n$ are the n Eigenvalues of the Laplacian matrix of a connected graph of n vertices

The # spanning trees of the graph is then

$$\frac{1}{n} \prod_{i=2}^n \mu_i$$

The 7 eigenvalues of the Laplacian Matrix are:

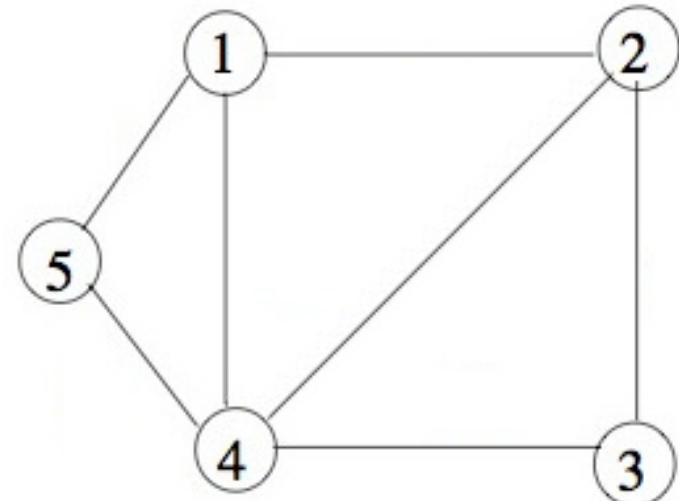
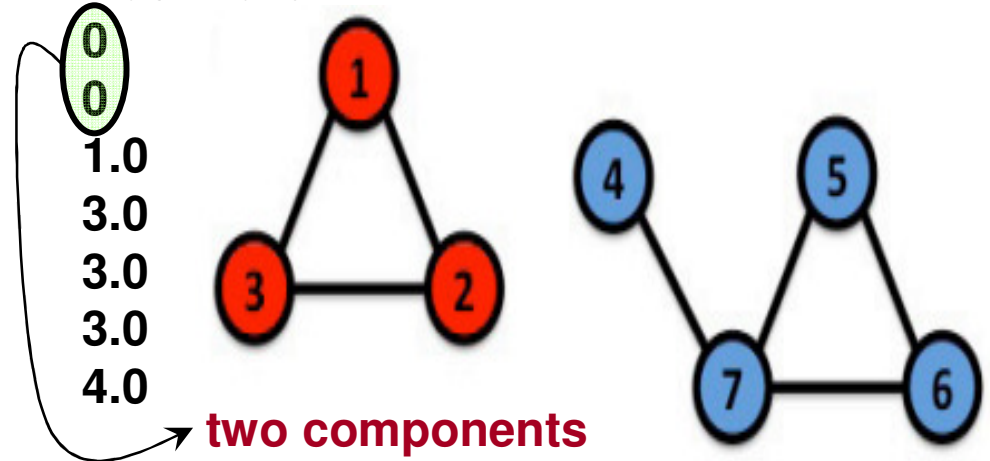

The five eigenvalues of the Laplacian matrix of the above graph are: 0, 1.586, 3.0, 4.414, 5.0

$$\# \text{ spanning trees} = (1/5)(1.586 \cdot 3 \cdot 4.414 \cdot 5) = 21.$$

Path Terminologies

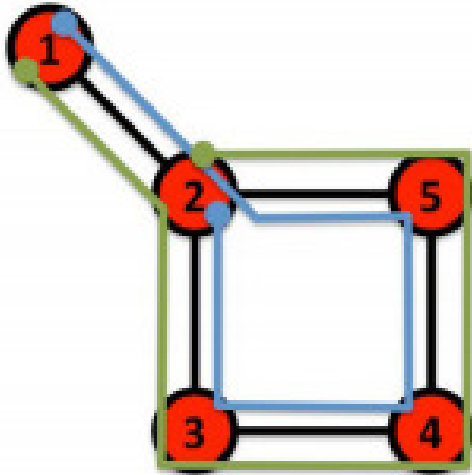

Eulerian Path

A path that traverses each link exactly once

Examples: 1 – 2 – 5 – 4 – 3 – 2

1 – 2 – 3 – 4 – 5 – 2

A node may be visited more than once.

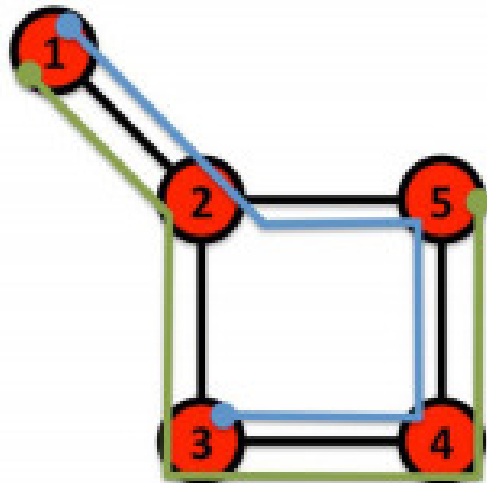

Hamiltonian Path

A path that traverses each node exactly once

Examples: 1 – 2 – 5 – 4 – 3

1 – 2 – 3 – 4 – 5

One or more links need not be traversed.

Eulerian Path and Circuit

- **Eulerian Path:** Start with a particular vertex, visit each edge exactly once (could visit a vertex more than once) and then end the trail at a vertex different from the starting vertex.

- There exists an Eulerian Path in a graph G only if G has exactly two vertices with odd degree and the rest of the vertices have even degree.

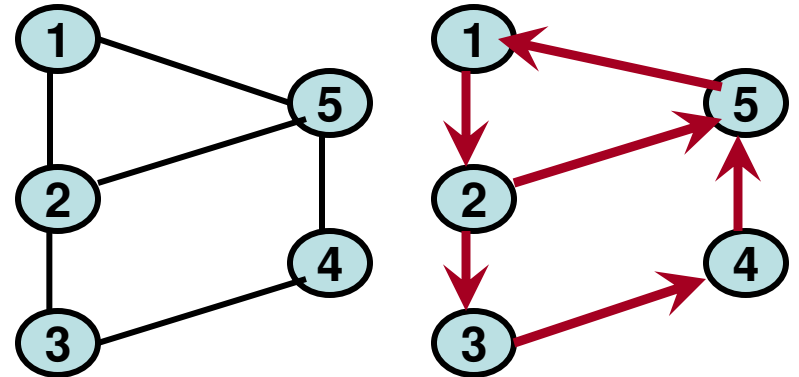

$V_2 \rightarrow V_5 \rightarrow V_1 \rightarrow V_2 \rightarrow V_3 \rightarrow V_4 \rightarrow V_5$

- **Eulerian Circuit:** Start with a particular vertex, visit each edge exactly once (could visit a vertex more than once) and then end the trail at the starting vertex.

- There exists an Eulerian Circuit in G only if every vertex in G has an even degree.

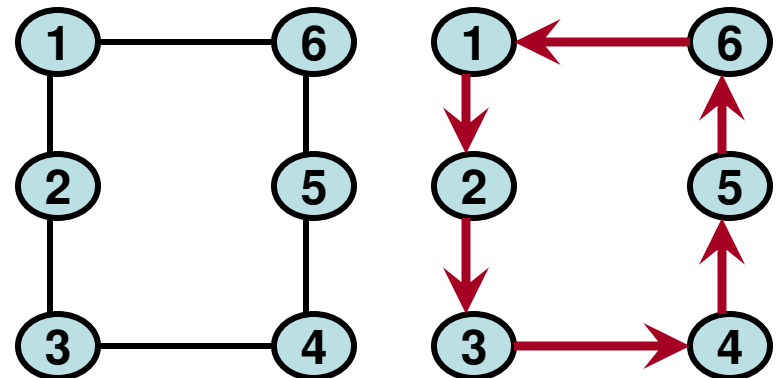

$V_1 \rightarrow V_2 \rightarrow V_3 \rightarrow V_4 \rightarrow V_5 \rightarrow V_6$

Depth First Search (DFS)

- Visits graph's vertices (also called nodes) by always moving away from last visited vertex to unvisited one, backtracks if there is no adjacent unvisited vertex.
- Break any tie to visit an adjacent vertex, by visiting the vertex with the lowest ID or the lowest alphabet (label).
- Uses a stack
 - a vertex is pushed onto the stack when it's visited for the first time
 - a vertex is popped off the stack when it becomes a dead end, i.e., when there is no adjacent unvisited vertex
- “Redraws” graph in tree-like fashion (with tree edges and back edges for undirected graph):
 - Whenever a new unvisited vertex is reached for the first time, it is attached as a child to the vertex from which it is being reached. Such an edge is called a tree edge.
 - While exploring the neighbors of a vertex, if the algorithm encounters an edge leading to a previously visited vertex other than its immediate predecessor (i.e., its parent in the tree), such an edge is called a back edge.
 - The leaf nodes have no children; the root node and other intermediate nodes have one more child.

Pseudo Code of DFS

ALGORITHM *DFS*(*G*)

```
//Implements a depth-first search traversal of a given graph
//Input: Graph  $G = \langle V, E \rangle$ 
//Output: Graph  $G$  with its vertices marked with consecutive integers
//      in the order they are first encountered by the DFS traversal
mark each vertex in  $V$  with 0 as a mark of being “unvisited”
count  $\leftarrow$  0
for each vertex  $v$  in  $V$  do
    if  $v$  is marked with 0
        dfs( $v$ )
```

dfs(v)

```
//visits recursively all the unvisited vertices connected to vertex  $v$ 
//by a path and numbers them in the order they are encountered
//via global variable count
count  $\leftarrow$  count + 1; mark  $v$  with count
for each vertex  $w$  in  $V$  adjacent to  $v$  do
    if  $w$  is marked with 0
        dfs( $w$ )
```

Example 1: DFS

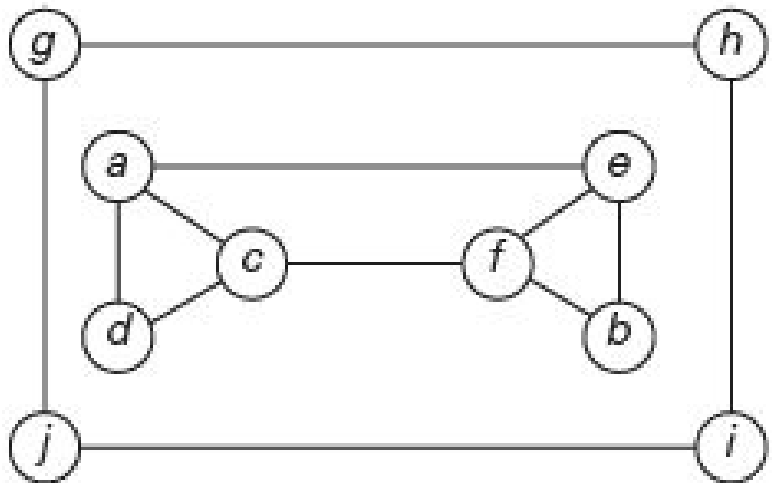

(a)

$d_{3,1}$
 $c_{2,5}$
 $a_{1,6}$
 $e_{6,2}$
 $b_{5,3}$
 $f_{4,4}$
 $j_{10,7}$
 $i_{9,8}$
 $h_{8,9}$
 $g_{7,10}$

(b)

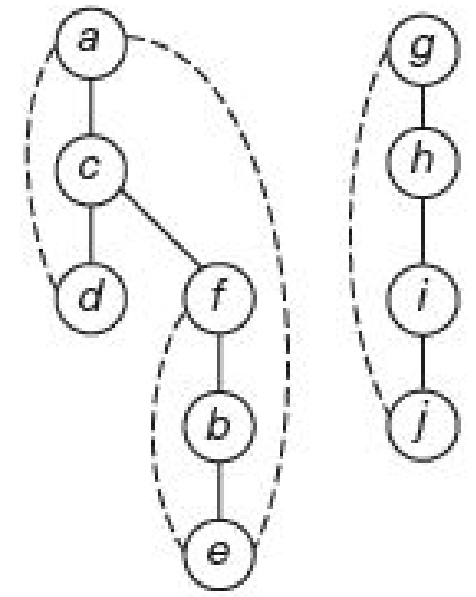

(c)

Example of a DFS traversal. (a) Graph. (b) Traversal's stack (the first subscript number indicates the order in which a vertex is visited, i.e., pushed onto the stack; the second one indicates the order in which it becomes a dead-end, i.e., popped off the stack). (c) DFS forest with the tree and back edges shown with solid and dashed lines, respectively.

Source: Figure 3.10: Levitin, 3rd Edition: Introduction to the Design and Analysis of Algorithms, 2012.

DFS

- DFS can be implemented with graphs represented as:
 - adjacency matrices: $\Theta(V^2)$; adjacency lists: $\Theta(|V|+|E|)$
- Yields two distinct ordering of vertices:
 - order in which vertices are first encountered (pushed onto stack)
 - order in which vertices become dead-ends (popped off stack)
- Applications:
 - checking connectivity, finding connected components
 - The set of vertices that we can visit through DFS, starting from a particular vertex in the set constitute a connected component.
 - If a graph has only one connected component, we need to run DFS only once and it returns a tree; otherwise, the graph has more than one connected component and we determine a forest – comprising of trees for each component.
 - checking for cycles (a DFS run on an undirected graph returns a back edge)
 - finding articulation points and bi-connected components
 - An articulation point of a connected component is a vertex that when removed disconnects the component.
 - A graph is said to have bi-connected components if none of its components have an articulation point.

Example 2: DFS

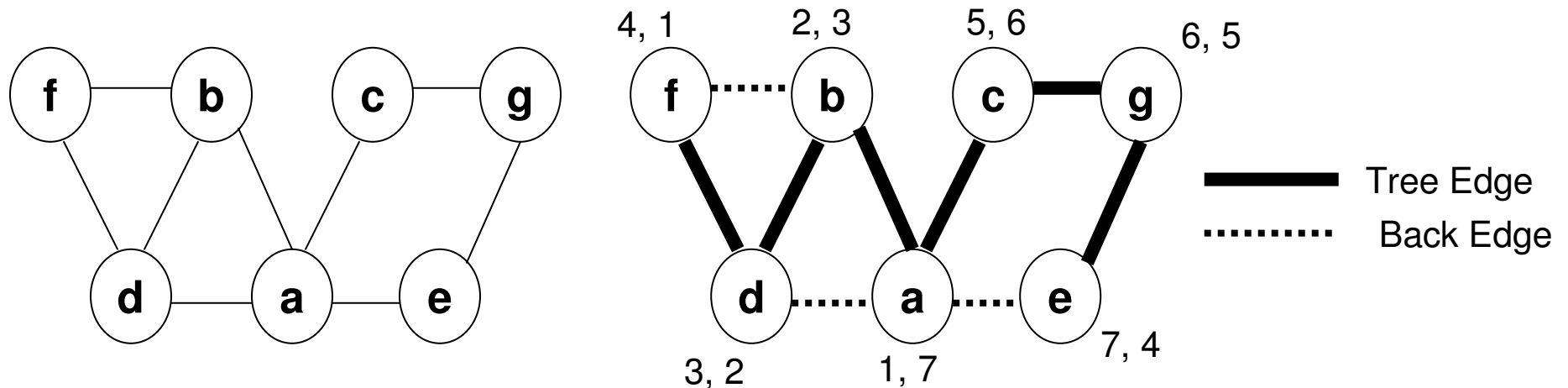

- Notes on Articulation Point

- The root of a DFS tree is an articulation point if it has more than one child connected through a tree edge. (In the above DFS tree, the root node 'a' is an articulation point)
- The leaf nodes of a DFS tree are not articulation points.
- Any other internal vertex v in the DFS tree, if it has one or more sub trees rooted at a child (at least one child node) of v that does NOT have an edge which climbs 'higher' than v (through a back edge), then v is an articulation point.

DFS: Articulation Points

Based on
Example 2

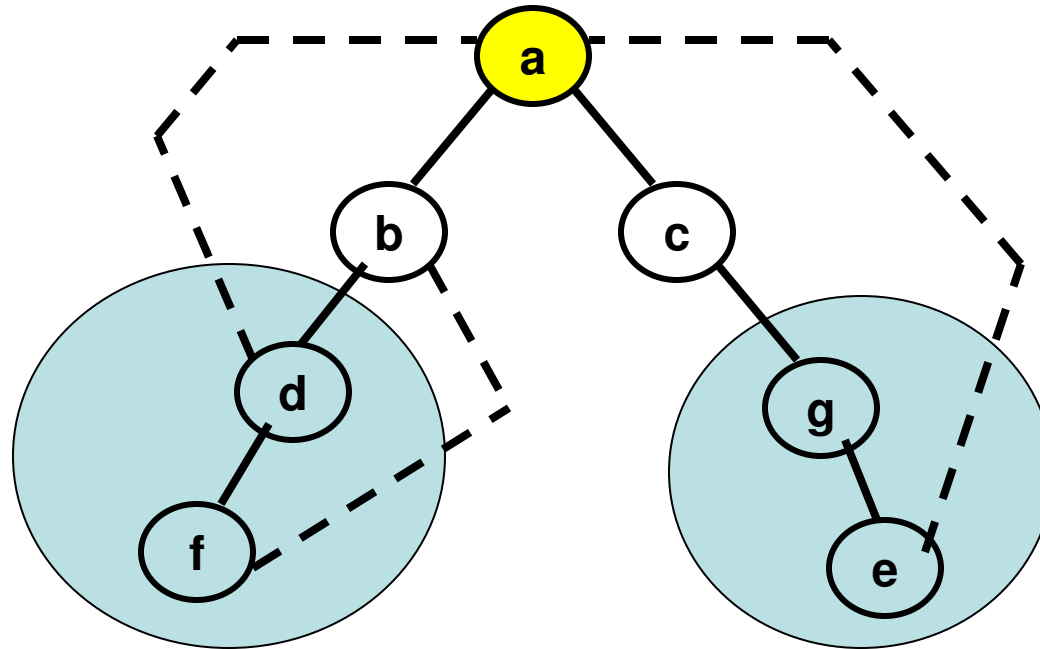

- In the above graph, vertex 'a' is the only articulation point.
- Vertices 'e' and 'f' are leaf nodes.
- Vertices 'b' and 'c' are candidates for articulation points. But, they cannot become articulation point, because there is a back edge from the only subtree rooted at their child nodes ('d' and 'g' respectively) that have a back edge to 'a'.
- By the same argument, vertices 'd' and 'g' are not articulation points, because they have only child node (f and e respectively); each of these child nodes are connected to a higher level vertex (b and a respectively) through a back edge.

Example 3: DFS and Articulation Points

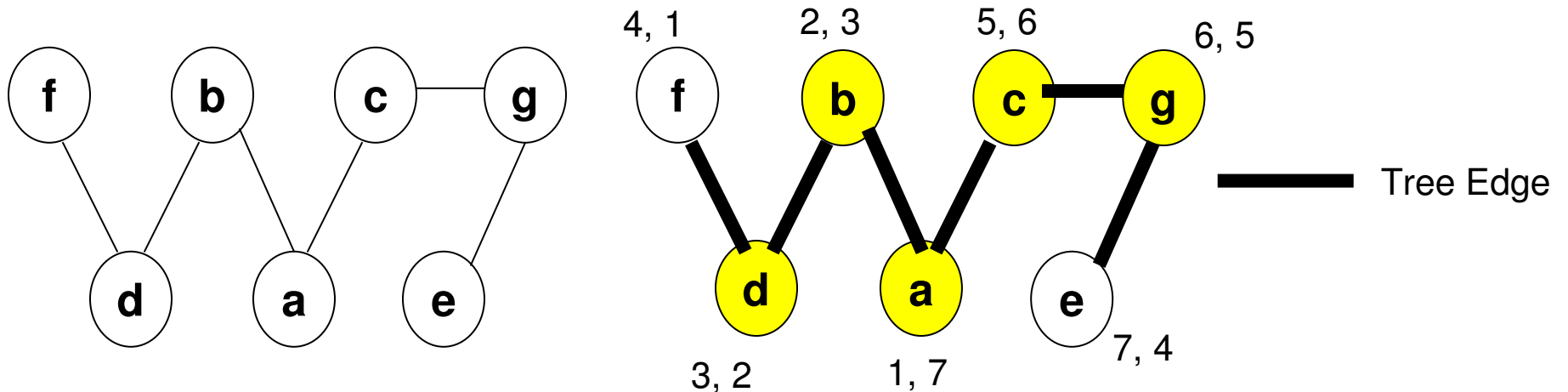

- In the above new graph (different from the previous example: note edges $b - f$, $a - d$ and $a - e$ are missing), vertices 'a', 'b', 'c', 'd' and 'g' are articulation points, because:
 - Vertex 'a' is the root node of the DFS tree and it has more than one child node
 - Vertex 'b' is an intermediate node; it has one sub tree rooted at its child node (d) that does not have any node, including 'd', to climb higher than 'b'. So, vertex 'b' is an articulation point.
 - Vertex 'c' is also an articulation point, by the same argument as above – this time, applied to the sub tree rooted at child node 'g'.
 - Vertices 'd' and 'g' are articulation points; because, they have one child node ('f' and 'e' respectively) that are not connected to any other vertex higher than 'd' and 'g' respectively.

Example 4: DFS and Articulation Points

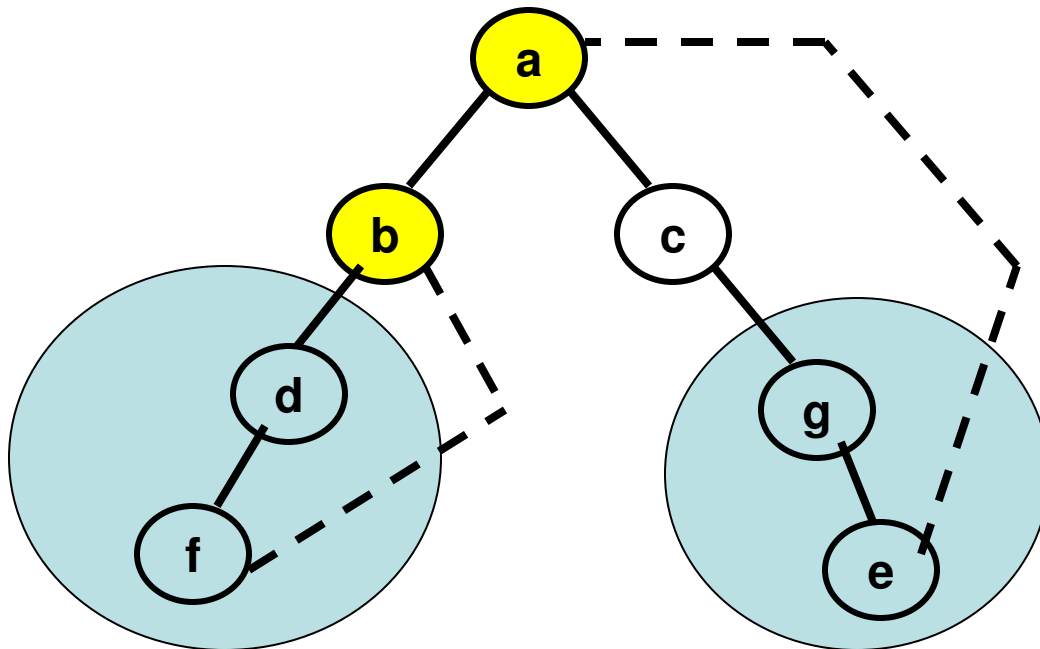
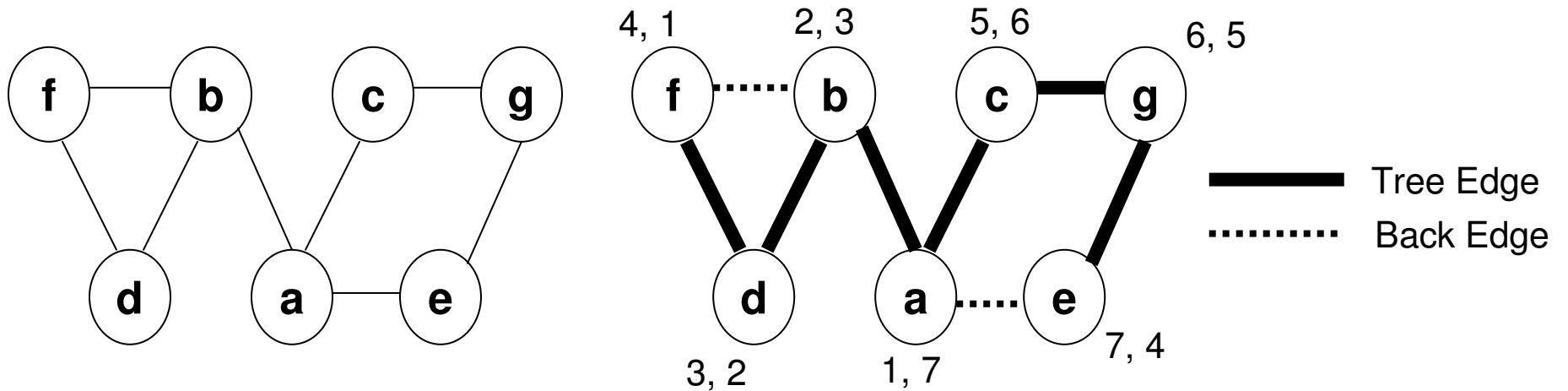

- In the above new graph (different from the previous example: note edge $a - e$ and $b - f$ are added back; but $a - d$ is missing):
 - Vertices 'a' and 'b' are articulation points
 - Vertex 'c' is not an articulation point

Example 5: DFS and Articulation Points

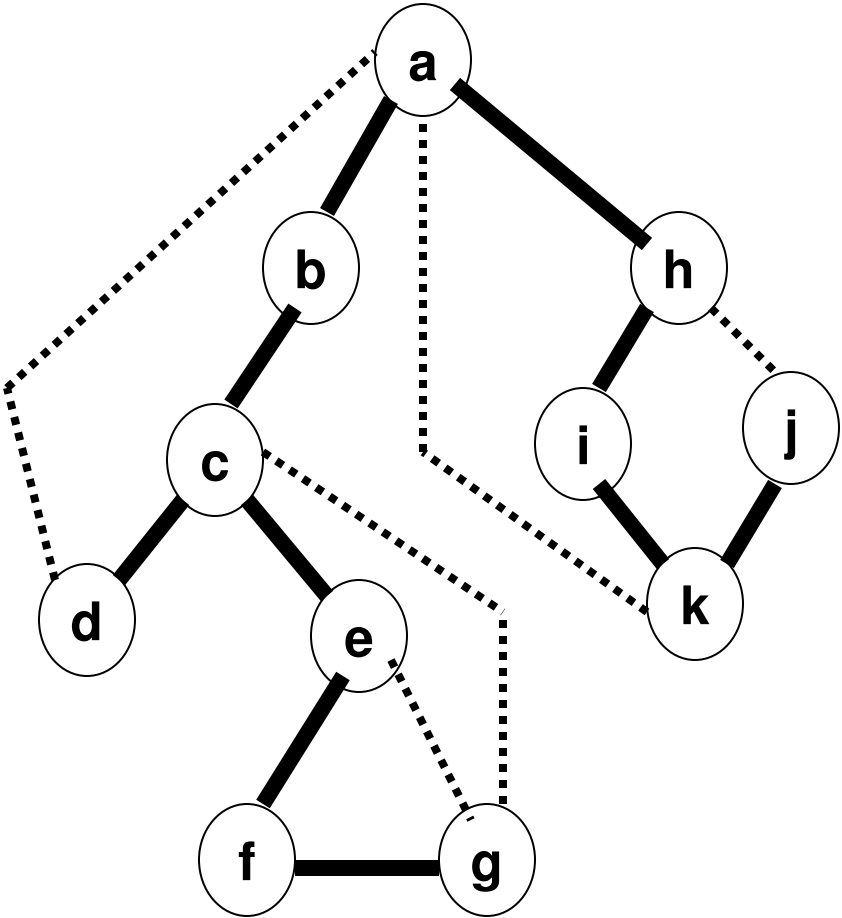
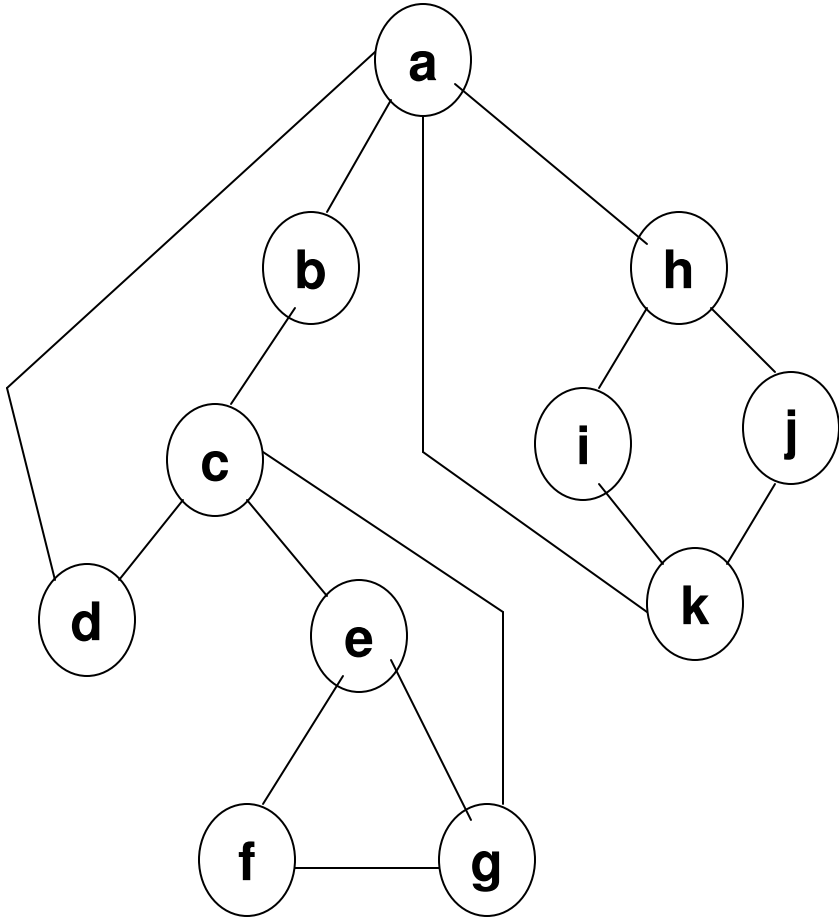

DFS TREE

Identification of the Articulation Points of the Graph in Example 5

1) **Root Vertex 'a'** has more than one child; so, it is an articulation point.

2) Vertices '**d**', '**g**' and '**i**' are leaf nodes

3) Vertex '**b**' is not an articulation point because the only sub tree rooted at its child node 'c' has a back edge to a vertex higher than 'b' (in this case to the root vertex 'a')

4) **Vertex 'c' is an articulation point.** One of its child vertex 'd' does not have any sub tree rooted at it. The other vertex 'e' has a sub tree rooted at it and this sub tree has no back edge higher up than 'c'.

5) By argument (4), it follows that vertex '**e**' is not an articulation point because the sub tree rooted at its child node 'f' has a back edge higher up than 'e' (to vertex 'c');

6) Vertices 'f' and 'k' are not articulation points because they have only one child node each and the child nodes are connected to a vertex higher above 'f' and 'k'.

7) Vertex 'i' is not an articulation point because the only sub tree rooted at its child has a back edge higher up (to vertices 'a' and 'h').

8) Vertex 'h' is not an articulation point because the only sub tree rooted at 'h' has a back edge higher up (to the root vertex 'a').

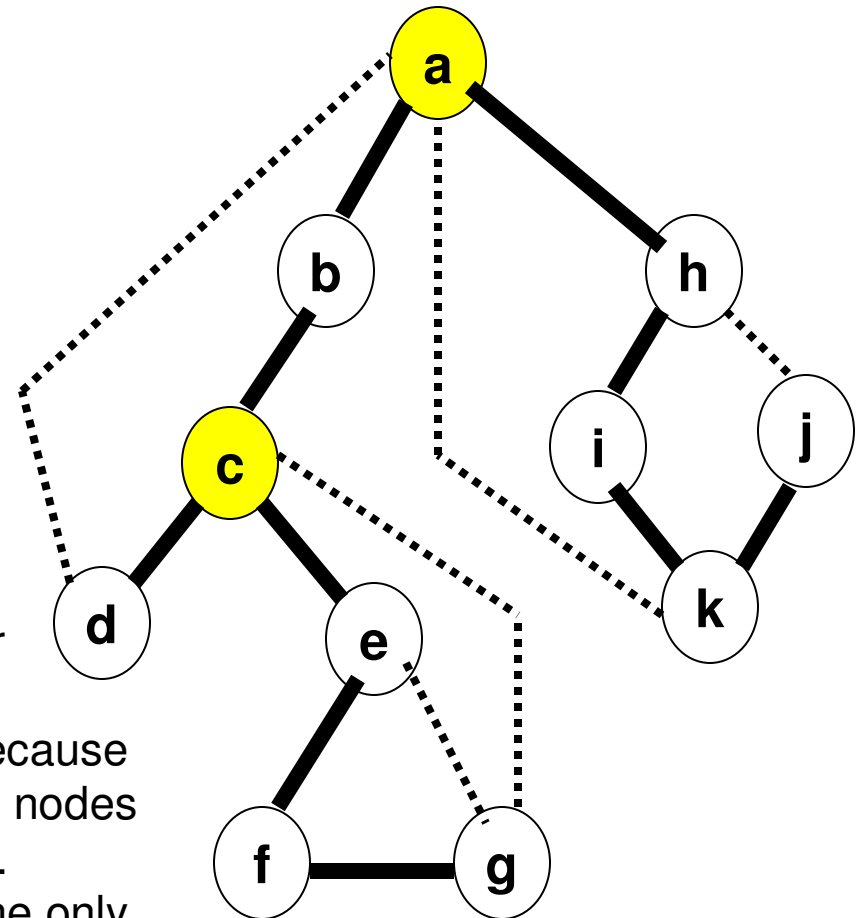

Breadth First Search (BFS)

- BFS is a graph traversal algorithm (like DFS); but, BFS proceeds in a concentric breadth-wise manner (not depth wise) by first visiting all the vertices that are adjacent to a starting vertex, then all unvisited vertices that are two edges apart from it, and so on.
 - The above traversal strategy of BFS makes it ideal for determining minimum-edge (i.e., minimum-hop paths) on graphs.
- If the underlying graph is connected, then all the vertices of the graph should have been visited when BFS is started from a randomly chosen vertex.
 - If there still remains unvisited vertices, the graph is not connected and the algorithm has to be restarted on an arbitrary vertex of another connected component of the graph.
- BFS is typically implemented using a FIFO-queue (not a LIFO-stack like that of DFS).
 - The queue is initialized with the traversal's starting vertex, which is marked as visited. On each iteration, BFS identifies all unvisited vertices that are adjacent to the front vertex, marks them as visited, and adds them to the queue; after that, the front vertex is removed from the queue.
- When a vertex is visited for the first time, the corresponding edge that facilitated this visit is called the tree edge. When a vertex that is already visited is re-visited through a different edge, the corresponding edge is called a cross edge.

Pseudo Code of BFS

ALGORITHM *BFS(G)*

//Implements a breadth-first search traversal of a given graph

//Input: Graph $G = \langle V, E \rangle$

//Output: Graph G with its vertices marked with consecutive integers

// in the order they are visited by the BFS traversal

mark each vertex in V with 0 as a mark of being “unvisited”

count \leftarrow 0

for each vertex v in V **do**

if v is marked with 0

bfs(v)

bfs(v)

//visits all the unvisited vertices connected to vertex v

//by a path and numbers them in the order they are visited

//via global variable *count*

count \leftarrow *count* + 1; mark v with *count* and initialize a queue with v

while the queue is not empty **do**

for each vertex w in V adjacent to the front vertex **do**

if w is marked with 0

count \leftarrow *count* + 1; mark w with *count*

 add w to the queue

 remove the front vertex from the queue

BFS can be implemented with graphs represented as:
adjacency matrices: $\Theta(V^2)$; adjacency lists: $\Theta(|V|+|E|)$

Example for BFS

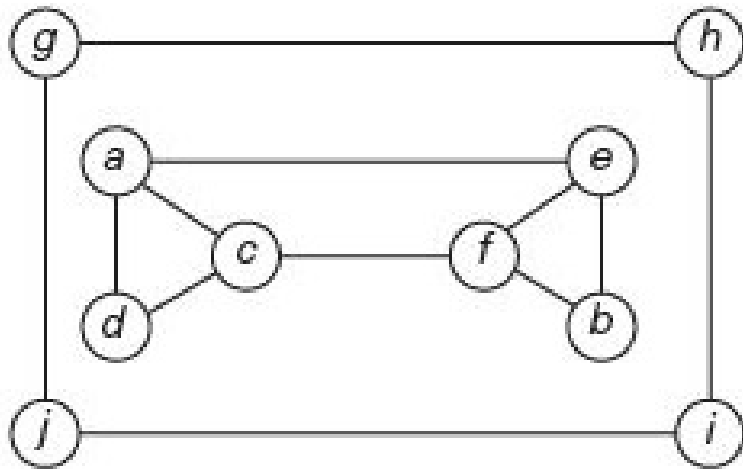

(a)

$a_1 c_2 d_3 e_4 f_5 b_6$
 $g_7 h_8 j_9 i_{10}$

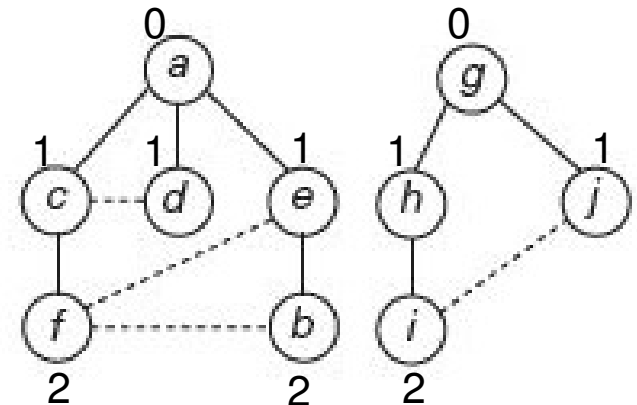

(b)

(c)

(a) Graph. (b) Traversal queue, with the numbers indicating the order in which the vertices are visited, i.e., added to (and removed from) the queue. (c) BFS forest with the tree and cross edges shown with solid and dotted lines, respectively.

Use of BFS to find Minimum Edge Paths

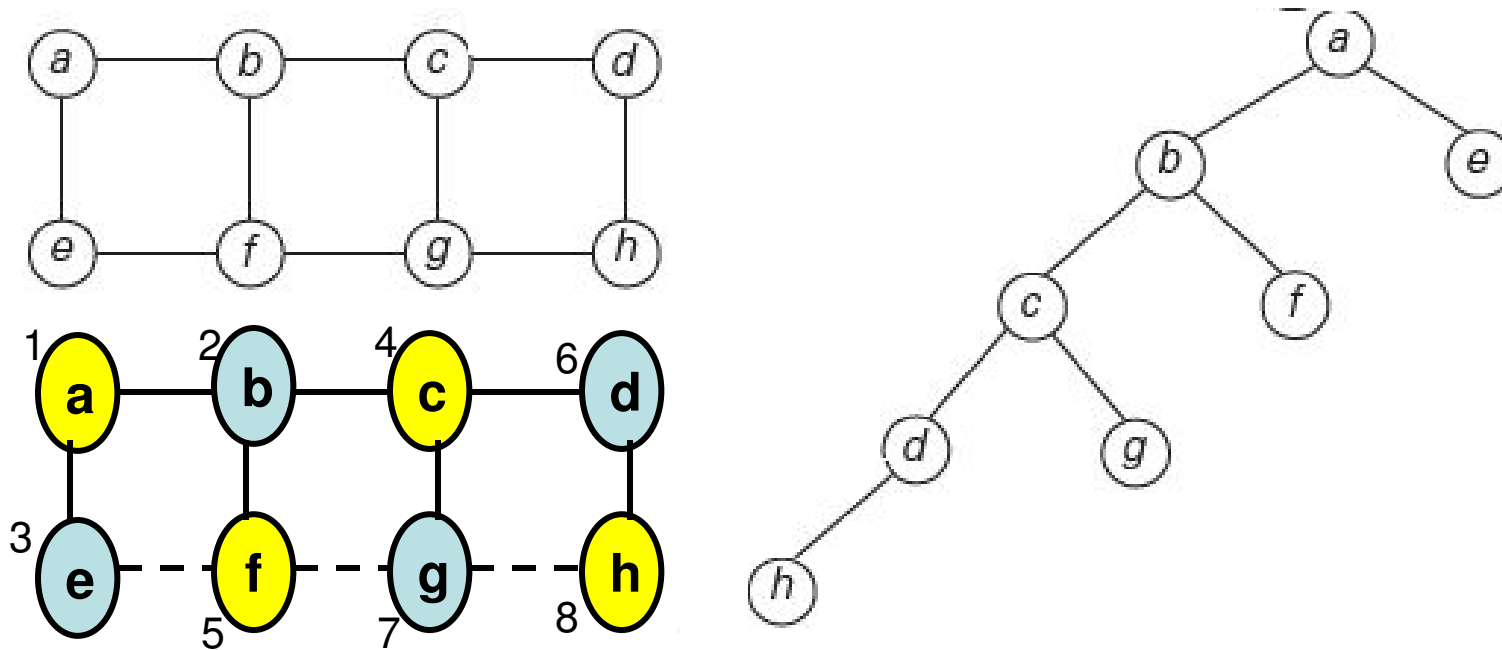

Note: DFS cannot be used to find minimum edge paths, because DFS is not guaranteed to visit all the one-hop neighbors of a vertex, before visiting its two-hop neighbors and so on.

For example, if DFS is executed starting from vertex 'a' on the above graph, then vertex 'e' would be visited through the path $a - b - c - d - h - g - f - e$ and not through the direct path $a - e$, available in the graph.

Comparison of DFS and BFS

	DFS	BFS
Data structure	a stack	a queue
Number of vertex orderings	two orderings	one ordering
Edge types (undirected graphs)	tree and back edges	tree and cross edges
Applications	connectivity, acyclicity, articulation points	connectivity, acyclicity, minimum-edge paths
Efficiency for adjacency matrix	$\Theta(V ^2)$	$\Theta(V ^2)$
Efficiency for adjacency lists	$\Theta(V + E)$	$\Theta(V + E)$

With the levels of a tree, referenced starting from the root node, A back edge in a DFS tree could connect vertices at different levels; whereas, a cross edge in a BFS tree always connects vertices that are either at the same level or at adjacent levels.

There is always only a unique ordering of the vertices, according to BFS, in the order they are visited (added and removed from the queue in the same order).

On the other hand, with DFS – vertices could be ordered in the order they are added to the Stack, typically different from the order in which they are removed from the stack.

Source: Table 3.1: Levitin, 3rd Edition: Introduction to the Design and Analysis of Algorithms, 2012.

Bi-Partite (2-Colorable) Graphs

- A graph is said to be bi-partite or 2-colorable if the vertices of the graph can be colored in two colors such that every edge has its vertices in different colors.
- In other words, we can partition the set of vertices of a graph into two disjoint sets such that there is no edge between vertices in the same set. All the edges in the graph are between vertices from the two sets.
- We can check for the 2-colorable property of a graph by running a DFS or BFS
 - With BFS, if there are no cross-edges between vertices at the same level, then the graph is 2-colorable.
 - With DFS, if there are no back edges between vertices that are both at odd levels or both at even levels, then the graph is 2-colorable.
- We will use BFS as the algorithm to check for the 2-colorability of a graph.
 - The level of the root is 0 (consider 0 to be even).
 - The level of a child node is 1 more than the level of the parent node from which it was visited through a tree edge.
 - If the level of a node is even, then color the vertex in yellow.
 - If the level of a node is odd, then color the vertex in green.

Bi-Partite (2-Colorable) Graphs

Example for a 2-Colorable Graph

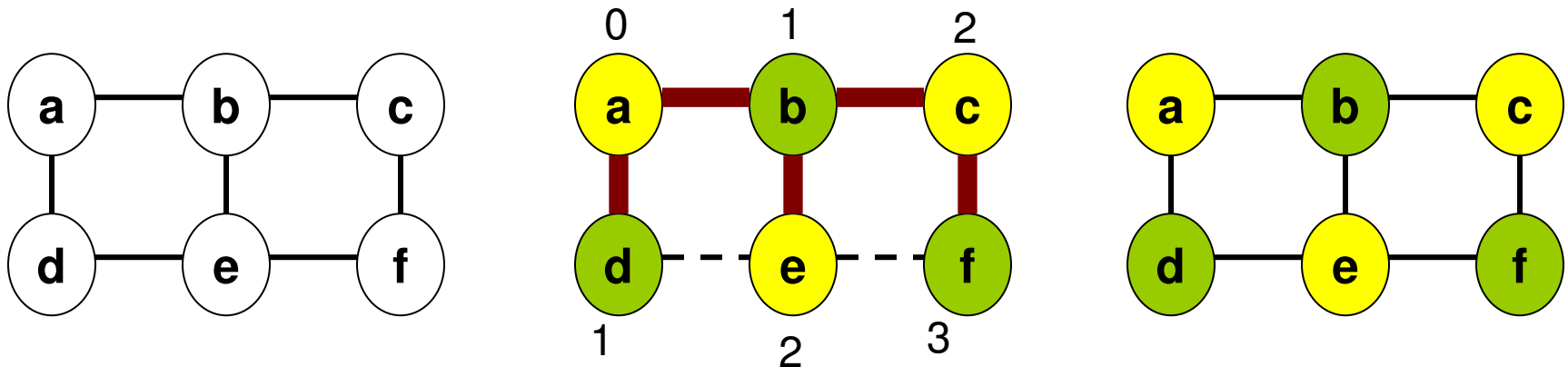

Example for a Graph that is Not 2-Colorable

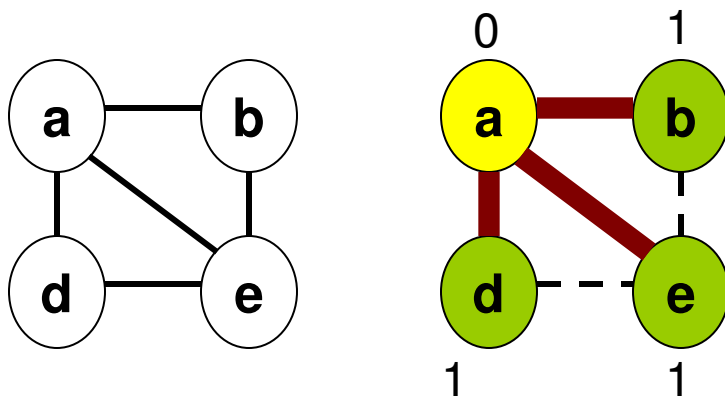

We encounter cross edges between vertices b and e; d and e – all the three vertices are in the same level.

Examples: 2-Colorability of Graphs

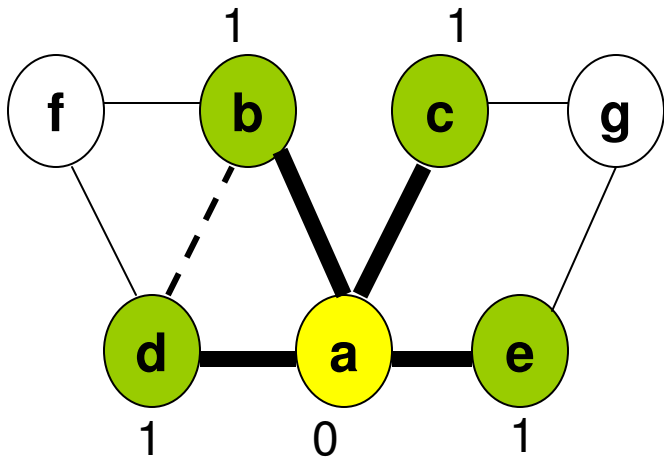
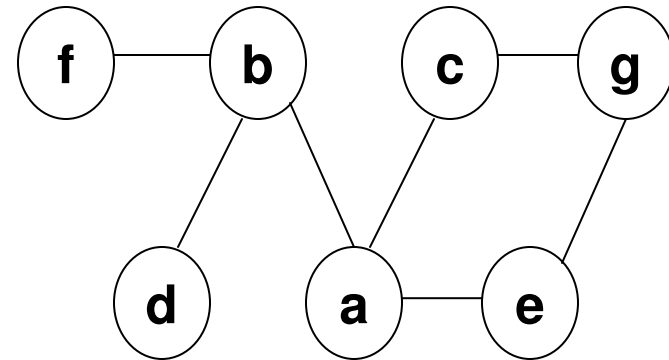
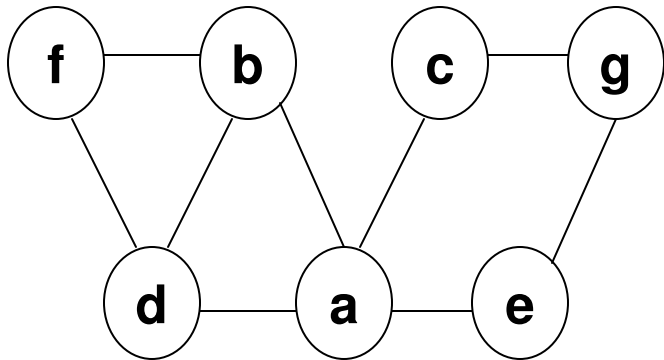

b – d is a cross edge between Vertices at the same level. So, the graph is not 2-colorable

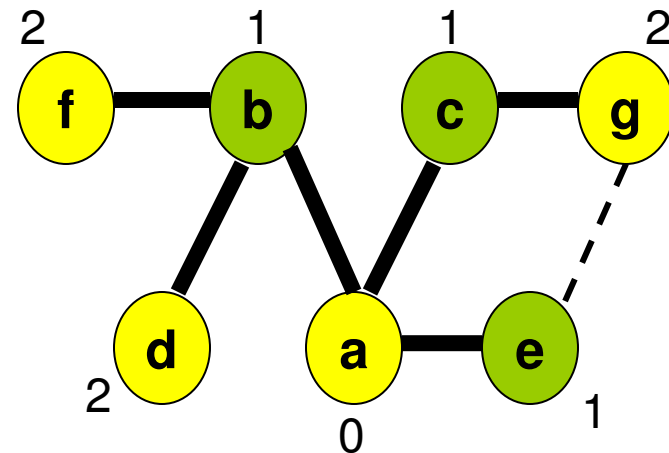

The above graph is 2-Colorable as there are no cross edges between vertices at the same level

Directed Acyclic Graphs (DAGs)

- A directed graph with no cycles.
 - E.g., Citation network: we always cite the work done earlier. A prior work does not cite a work to be done later.
- In a DAG, there must be at least one vertex that has only all incoming edges and no outgoing edge.
 - We start with one vertex, go around the vertices in the graph. If the path never reaches a vertex with no outgoing edges, then it must eventually arrive back at a vertex that has been visited previously – at most we can visit all the n vertices in the graph once before the path either terminates or we are forced to revisit a vertex (in the latter case, we encounter a cycle).
- To test for cycle: Remove the vertices with no outgoing edges (and all the associated incoming edges), one by one. If there is a cycle, there will be a scenario in which we could not find any vertex without outgoing edges.
 - If all vertices could be removed one by one, the graph is acyclic.

DFS on a DAG

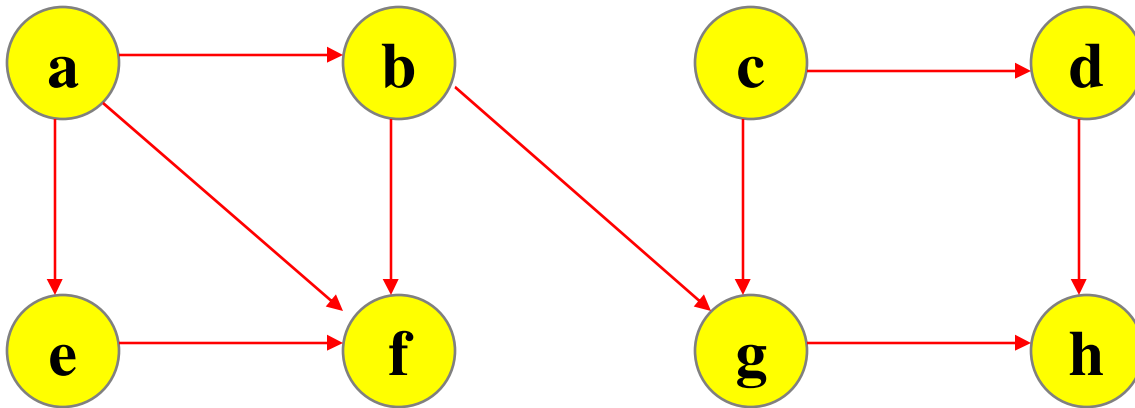

$h_{5,2}$
 $g_{4,3}$
 $f_{3,1}$
 $b_{2,4}$ $e_{6,5}$ $d_{8,7}$
 $a_{1,6}$ $c_{7,8}$

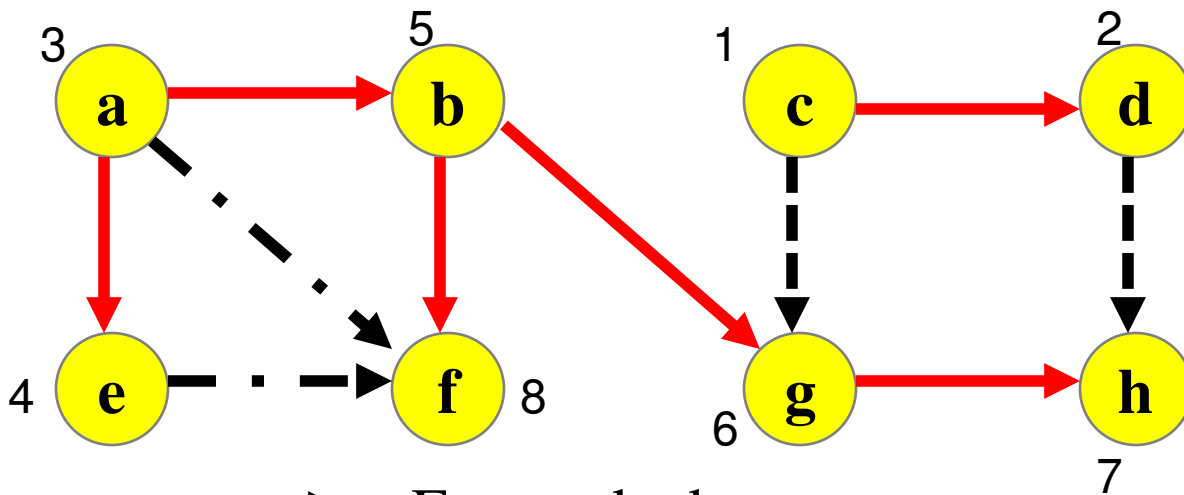

Forward edge
 Cross edge

Order in which the Vertices are popped of from the stack

f h g b e a d c

Reverse the order

Topological Sort

c d a e b g h f

DFS on a DAG

	1	2	3	4	5	6	7	8
1	0	1	0	0	0	1	0	0
2	0	0	0	0	0	0	1	0
3	0	0	0	1	1	0	0	1
4	0	0	0	0	0	0	0	1
5	0	0	0	0	0	1	0	1
6	0	0	0	0	0	0	1	0
7	0	0	0	0	0	0	0	0
8	0	0	0	0	0	0	0	0

Let the vertices be numbered in the order in which they are topologically sort.

An adjacency matrix of the vertices listed in the order of their topological sort is strictly upper triangular.

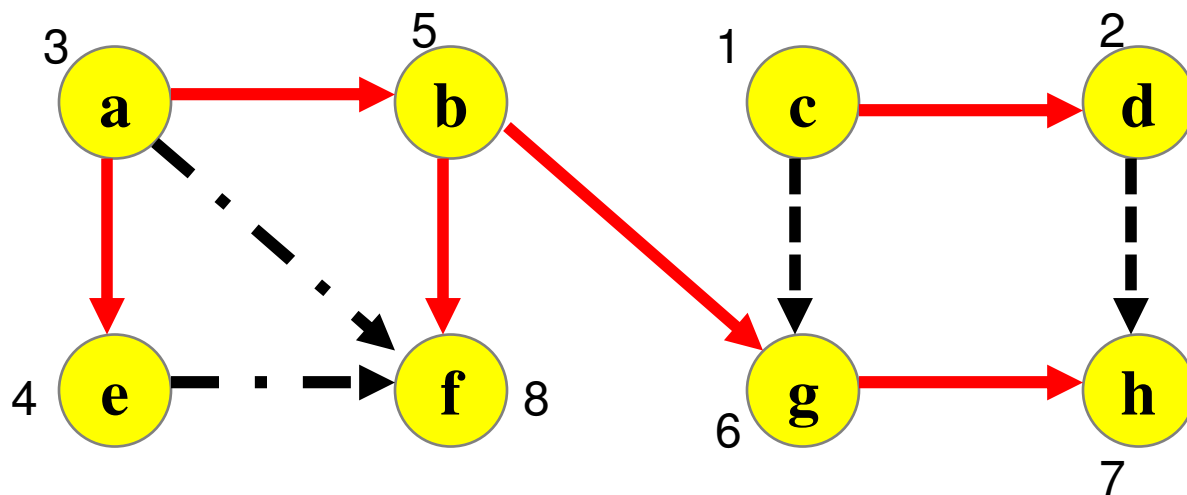

Components

- Component: The subset of vertices in a graph that are reachable from one another through paths of length one or more.
- Maximal subset property of a component: Inclusion of additional edges or vertices from the graph to this subset will break the connectivity of a component.
- A graph in which all its vertices are not in one component is said to be disconnected.
 - Undirected graph: The set of all vertices that are reachable (via BFS or DFS) starting from a particular vertex are all said to be in the same component.
 - Directed graph:
 - Weakly connected: The vertices of a di-graph are said to form a weakly connected component if they are connected in their undirected version.
 - Strongly connected: The vertices of a di-graph are said to form a strongly connected component if they are connected (reachable from each other through paths).
 - A standalone vertex that is not reachable to and from any other vertex is said to be in its own component.

Components: Examples

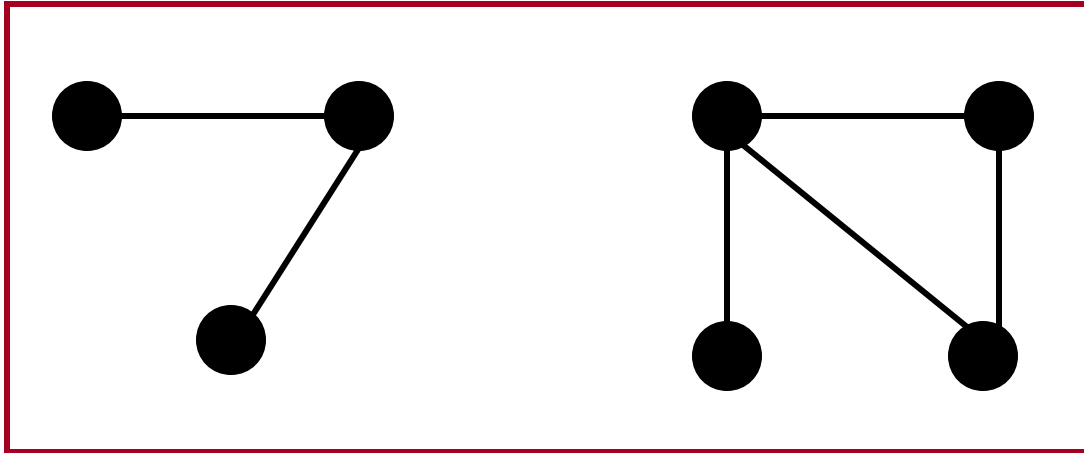

**Undirected graph with
Two components**

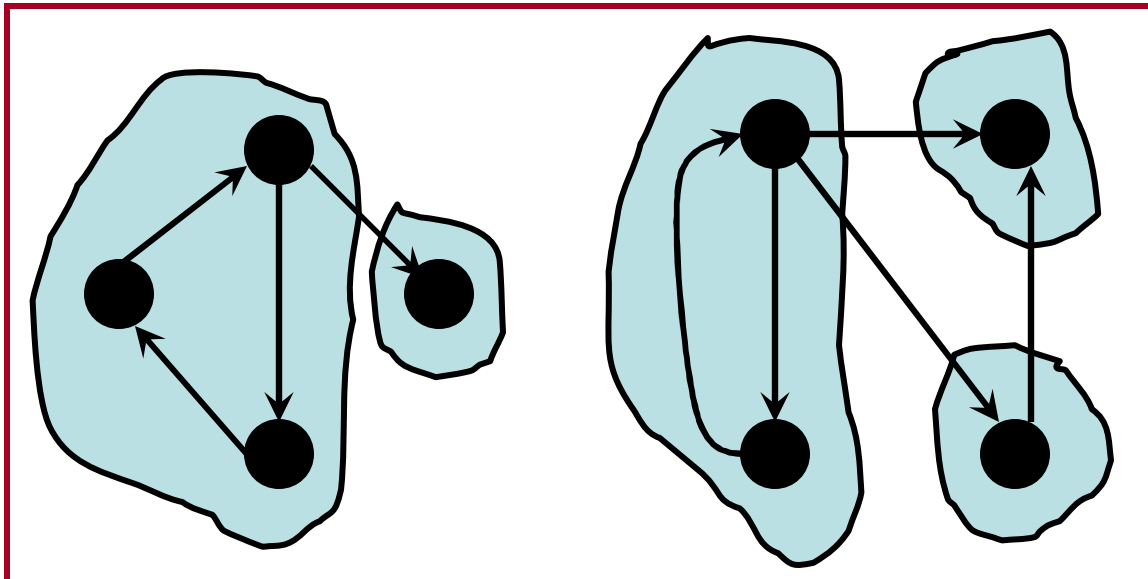

Directed graph with

**Two weakly connected
Components**

**Five strongly connected
components**

Components in a DAG

- Note that for a directed graph to have a strongly connected component (scc), the graph should have a cycle: because, we need the vertices in an scc to be reachable from one another.
 - There has to be a path from A to B through a sequence of edges and vice-versa through a different sequence of edges.
- Hence, there cannot be a strongly connected component in a DAG.

Out- and In- Components

- The out-component (defined for a specific vertex A) in a directed graph is the set of all vertices (including A itself) that are reachable from A through one or more paths.
- The in-component (defined for a specific vertex A) in a directed graph is the set of all vertices (including A itself) that have a directed path to A .
- The intersection of both the out-component and in-component of A yields a strongly connected component (scc) involving vertex A . All the vertices in such a scc are reachable from each other at least through A .

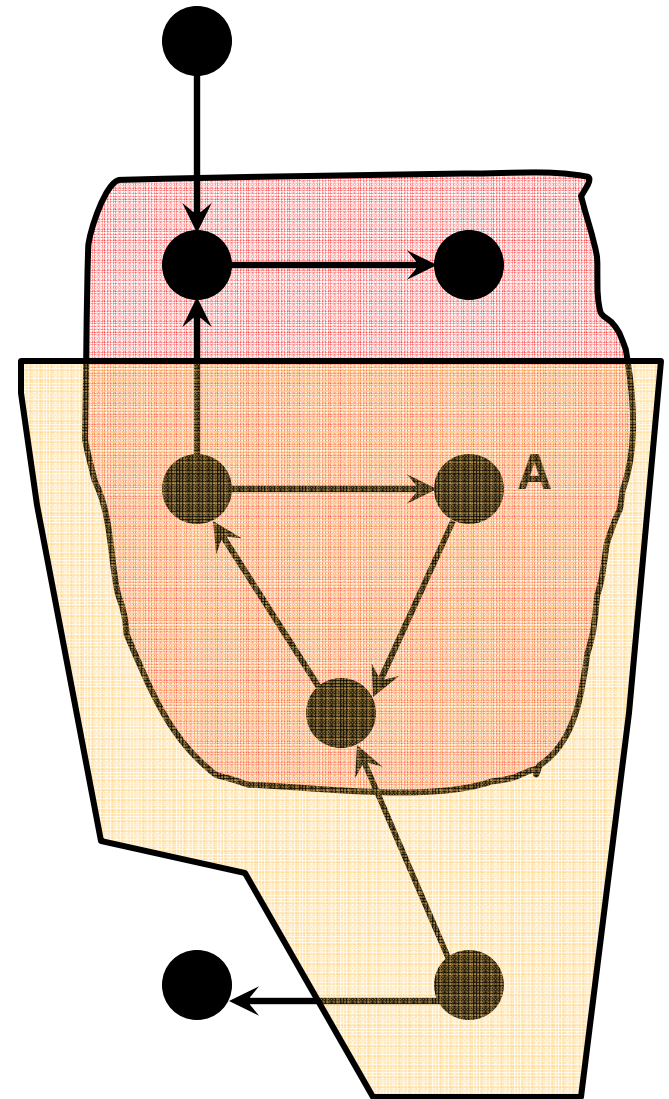

Algorithm to Find Strongly Connected Components in a Di-Graph

- Let G be a directed graph and SCC-Stack (S) be an empty stack.
- While SCC-Stack does not contain all vertices:
 - Choose an arbitrary vertex v not in S . Perform a DFS starting at v . Each time DFS pops out a vertex u from its stack (note: the DFS stack), push u onto the SCC-Stack.
- Reverse the directions of all edges to obtain the transpose graph of G .
- While the SCC-Stack is nonempty:
 - Pop the top vertex v from S . Perform a DFS starting at v in the transpose graph. The set of visited vertices will give the strongly connected component containing v ; record this and remove all these vertices from the graph G and the stack S .
- Time complexity: Two DFS: $\Theta(V+E)$.

Finding Strongly Connected Components

Original Graph

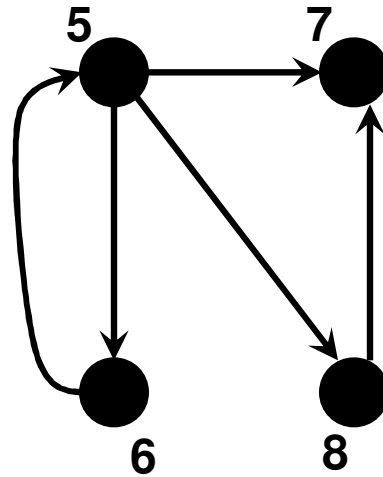
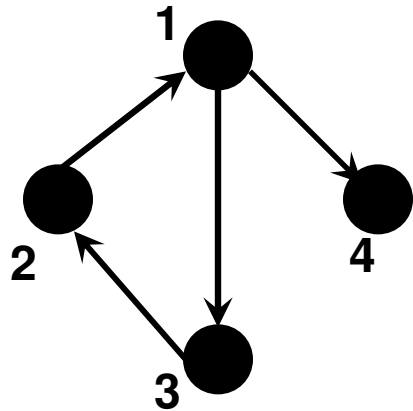

SCC Stack

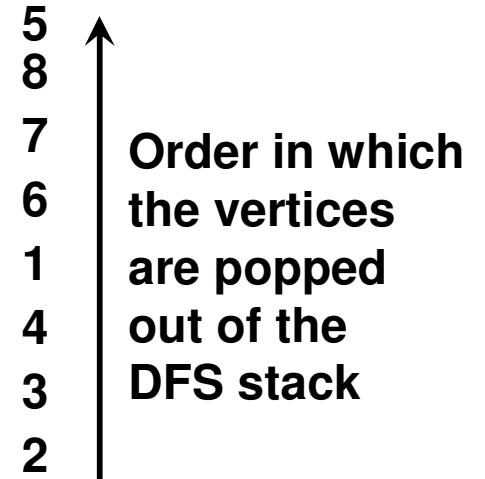

Transpose Graph

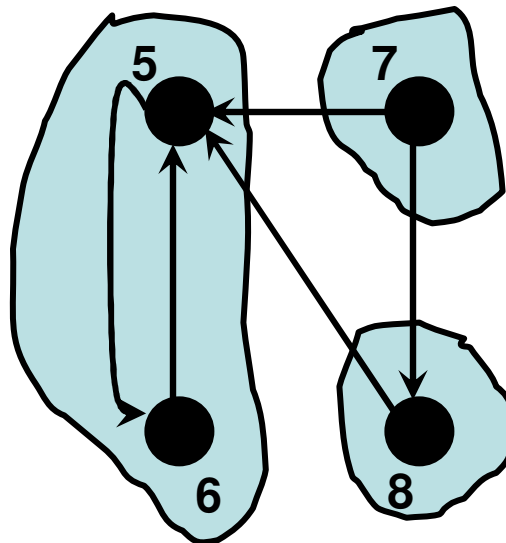
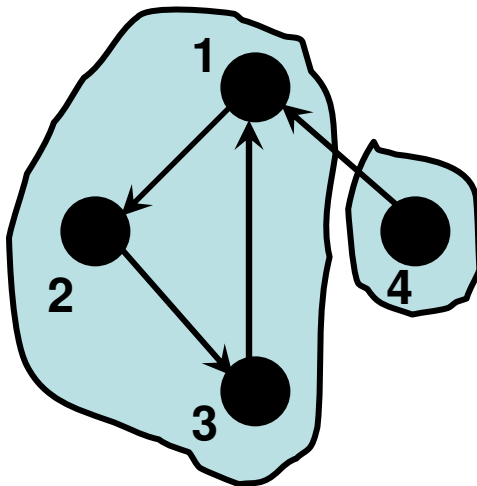

DFS Traversals

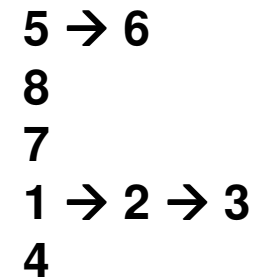

Finding Strongly Connected Components

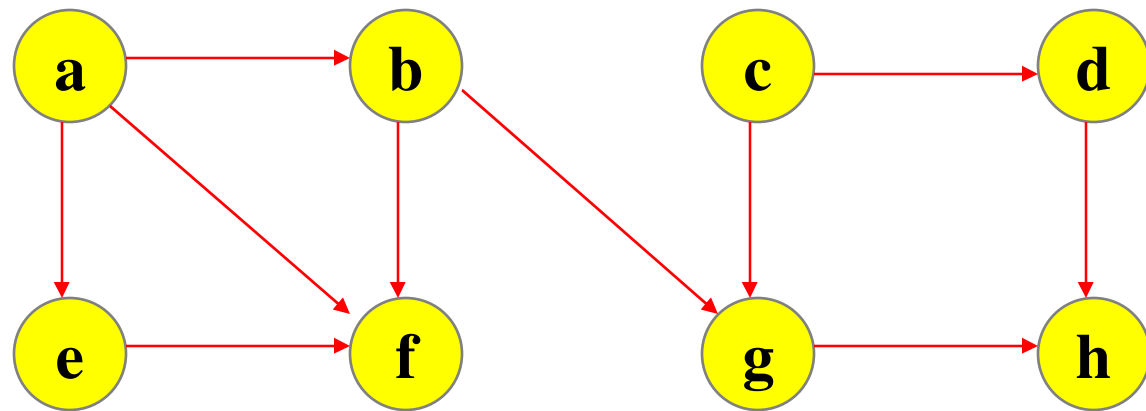

$h_{5,2}$
 $g_{4,3}$
 $f_{3,1}$
 $b_{2,4}$ $e_{6,5}$ $d_{8,7}$
 $a_{1,6}$ $c_{7,8}$

SCC Stack

c
 d
 a
 e
 b
 g
 h
 f

↑

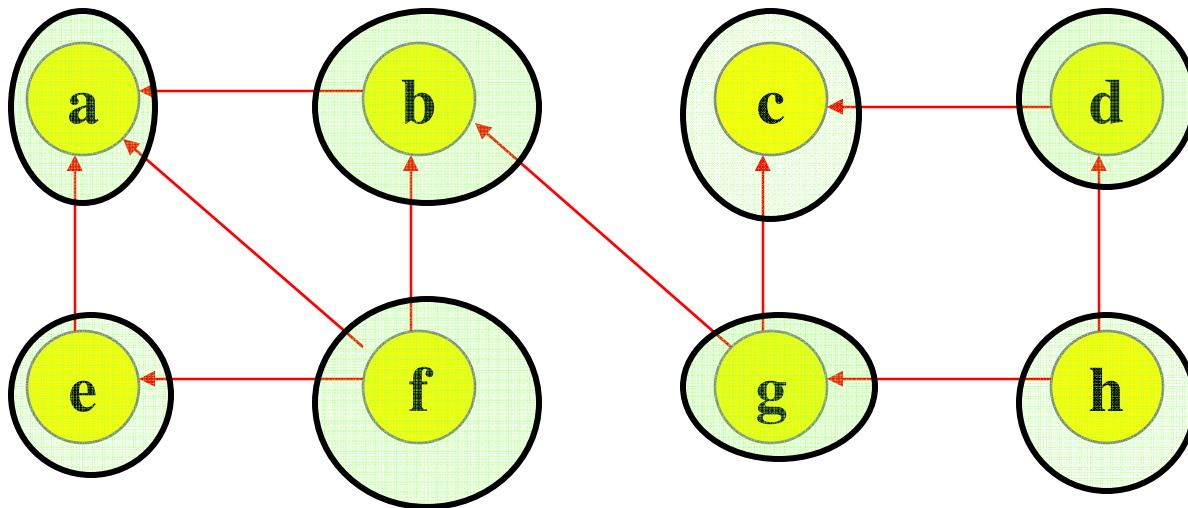

DFS Traversals

c
 d
 a
 e
 b
 g
 h
 f

Vertex Connectivity, Edge Connectivity

- Consider the set of paths between two vertices A and B.
- Vertex-disjoint paths: Two paths are said to be vertex-disjoint if there is no common intermediate vertex between the two paths.
- Edge-disjoint paths: Two paths between are said to be edge-disjoint if there is no common edge between the two paths.
- Vertex Connectivity between two vertices A and B is the number of vertex-disjoint paths between A and B.
- Edge Connectivity between two vertices A and B is the number of edge-disjoint paths between A and B.

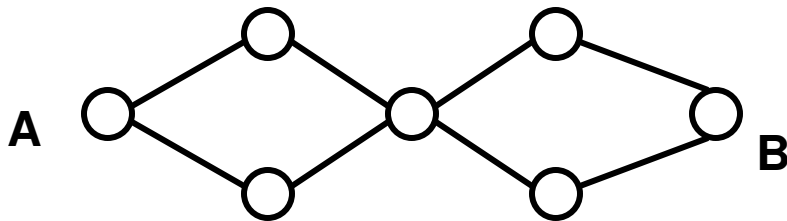

Vertex Connectivity – 1
Edge Connectivity – 2

Connectivity: Good or bad?

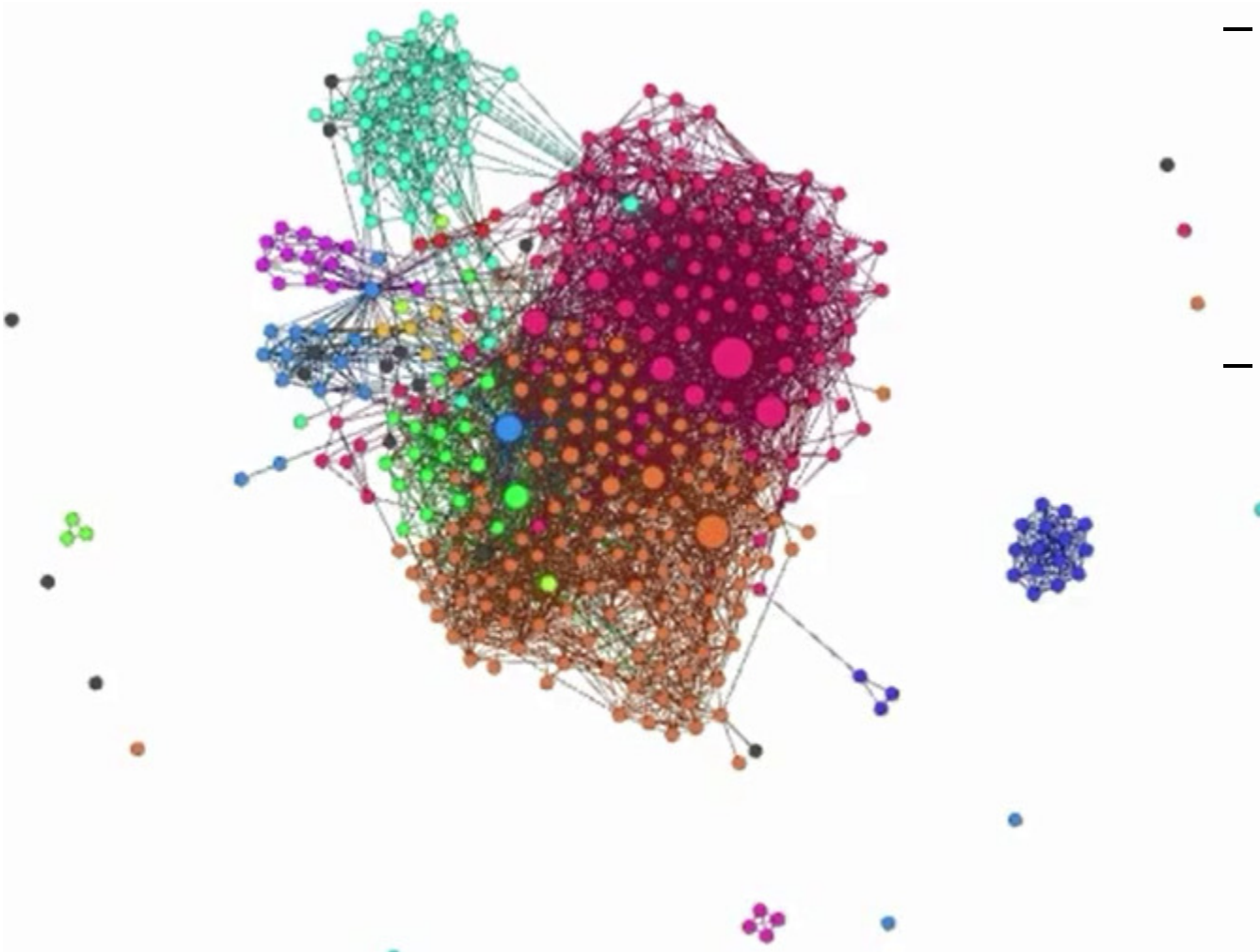

- It depends:
 - Spread of good news – want to stay in a bigger connected component as in the center ones
 - Spread of virus – want to stay in a smaller connected component like the smaller ones so that you are less likely to be attacked.

Local Clustering Coefficient

- The local clustering coefficient captures the degree to which the neighbors of a given node link to each other.
- If k_i is the degree of node i , then the maximum number of links between its k_i neighbors is $k_i * (k_i - 1) / 2$.
- Let L_i be the number of links among the neighbors of node i . Local clustering coefficient of node i is

Local clustering coefficient is a measure of the neighborhood density. Larger the value, more dense is the neighborhood and vice-versa.

$$C_i = \frac{L_i}{\left[\frac{k_i(k_i - 1)}{2} \right]}$$

- The local clustering coefficient is a probability that any two neighbor nodes of a node are linked to each other.
- Average Clustering Coefficient

Is a measure of the probability that any two neighbor nodes of a randomly selected node are linked to each other.

$$\langle C \rangle = \frac{1}{N} \sum_{i=1}^N C_i$$

Examples for Local Clustering Coefficients

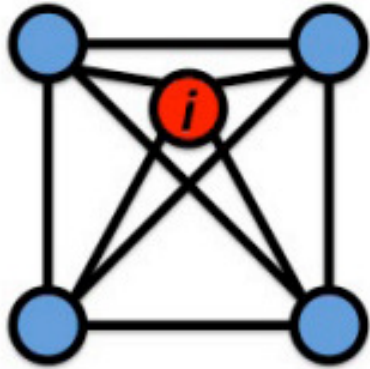

$$C_i = 1$$

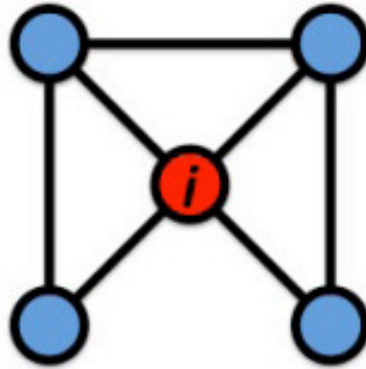

$$C_i = 1/2$$

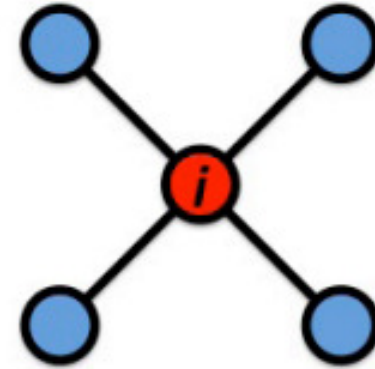

$$C_i = 0$$

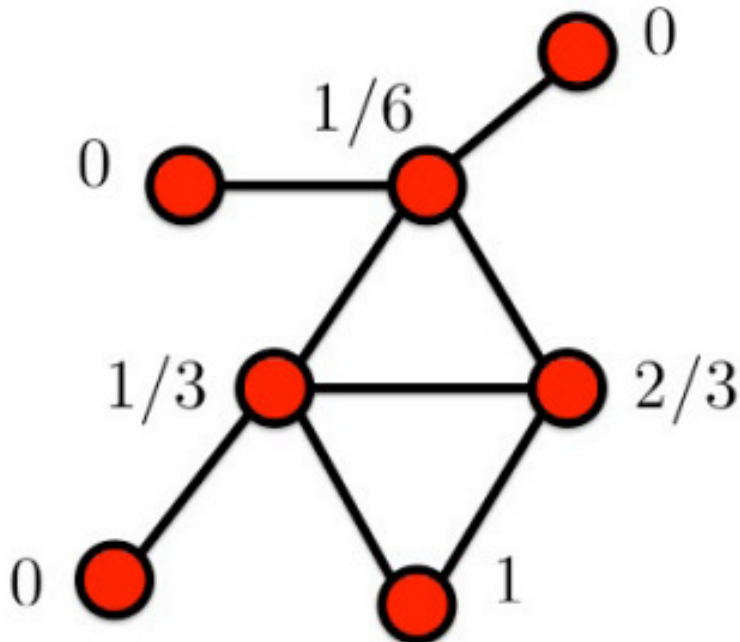

$$\langle C \rangle = \frac{13}{42} \approx 0.310$$

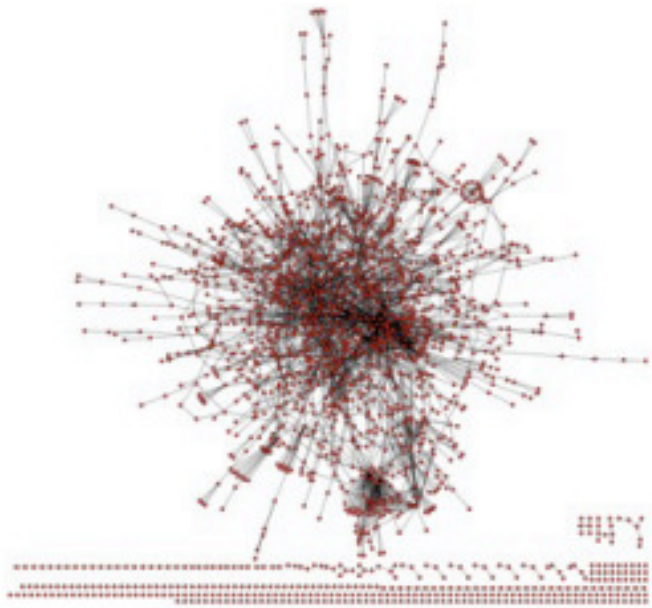

Any two nodes are connected within a shorter distance

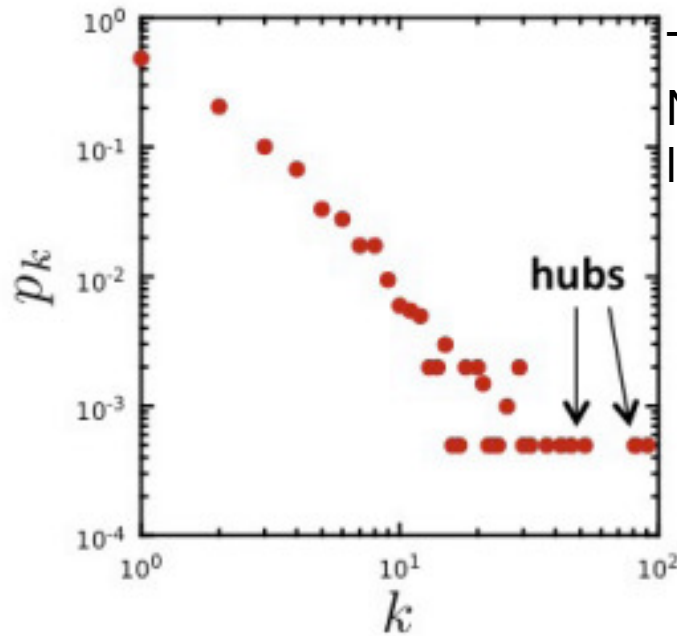
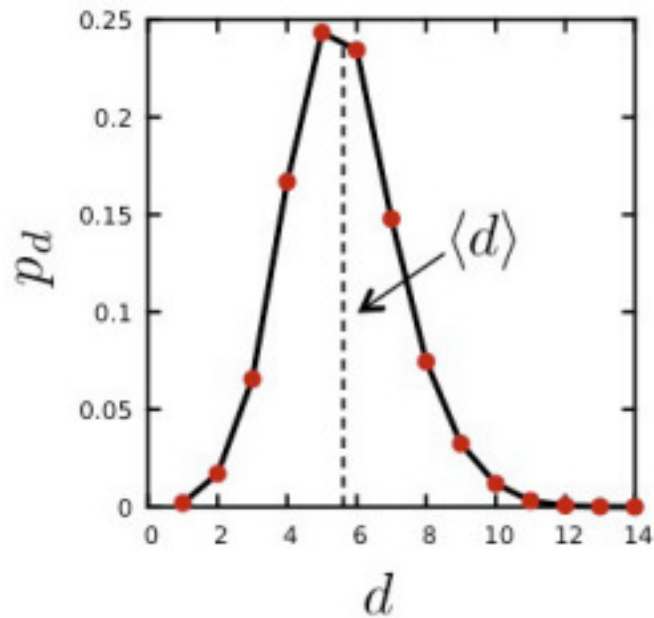

The probability of finding Nodes with degree less than 3 is 69%

Case Study: PPI

Network of Yeast

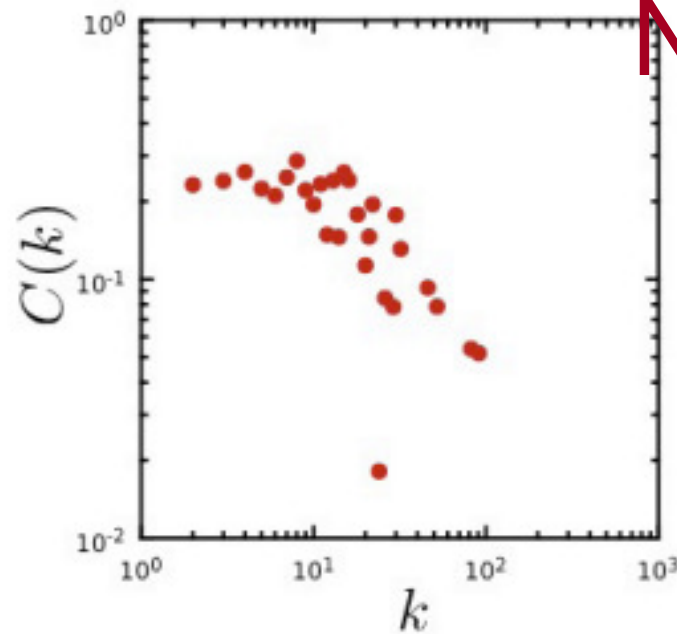

Nodes that have a high degree do not have a dense neighborhood. The contrary is observed.

Network Types: Terminologies

- Complement of a network G : Is a network comprising of all the nodes in G but comprising of links (between nodes) that are not in G .
- Regular network: An r -regular network is a network in which each node has degree r and such a network of n nodes has $rn/2$ links.
- Complete network: comprises of links between any two nodes
- Empty network: Complement of a complete network
- K -Colorability: A network is k -colorable if for any link in the network, the end vertices are colored in different colors, chosen among the k colors.
- Bipartite networks: The network is partitioned to two disjoint (non-empty) subsets $V1$ and $V2$ such that $V1 \cup V2 = V$, the set of all vertices and the only edges in the network are those that connect a vertex in $V1$ to a vertex in $V2$.
 - There are no edges between any two vertices within $V1$ or $V2$.
- Planar Networks: The network can be drawn in such a way (in a plane) that no two edges intersect (except at the end nodes).
- K -partite networks: The network is partitioned into k -disjoint subsets; such that any edge in the network is between the vertices across any two of these subsets.

Planar Graph (1)

- A planar graph is one which can be drawn in the plane (say, on paper) with no intersecting edges.
- A complete graph on 5 vertices (K_5) and a complete bipartite graph of 3-3 vertices ($K_{3,3}$) are not planar.
- Test for planarity:
 - **Necessary Condition (note these are not sufficient conditions, hence, can be used to decide only if it is NOT planar):** If a graph $G = (V, E)$ is connected and has 3 or more vertices,

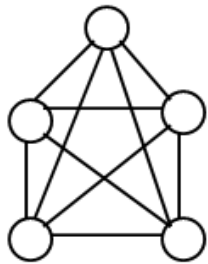

- If there is no cycle of length 3 (i.e., NO triangle),
 - If $|E| > (2|V| - 4)$, then G is not planar.
- Otherwise,
 - If $|E| > (3|V| - 6)$, then G is not planar.

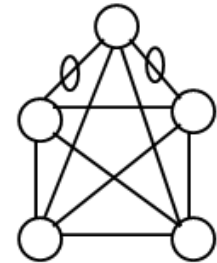
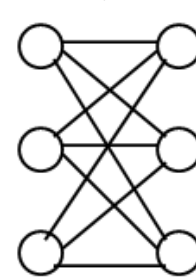

- **Test:** Check if the graph G has any K_5 or $K_{3,3}$ imbedded in it. If so, then G is not planar.
 - Theorem: A non-planar graph H cannot be a sub graph of a planar graph G .
- Note that we may need to smoothen a graph G (i.e., remove all 2-valent vertices, vertex with two edges only) and if the smoothened graph has any K_5 or $K_{3,3}$ imbedded in it, then G is not planar.

10 vertices, 18 edges there is a cycle of length 3

$$18 \not> 3(10) - 6;$$

Passes test for necess. condition

Planar Graph (2)

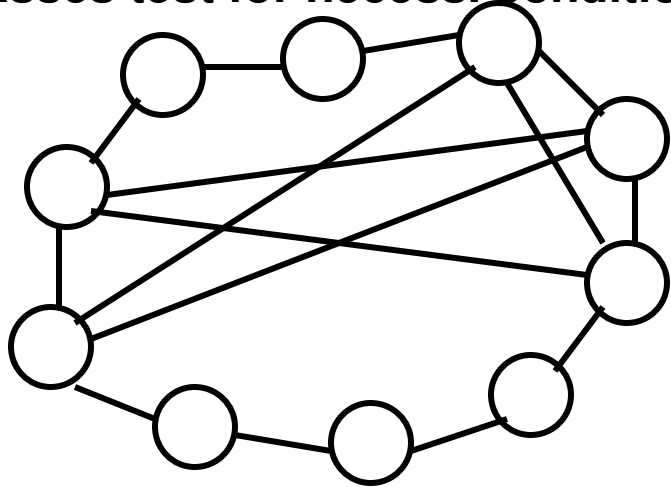

After
Smoothening

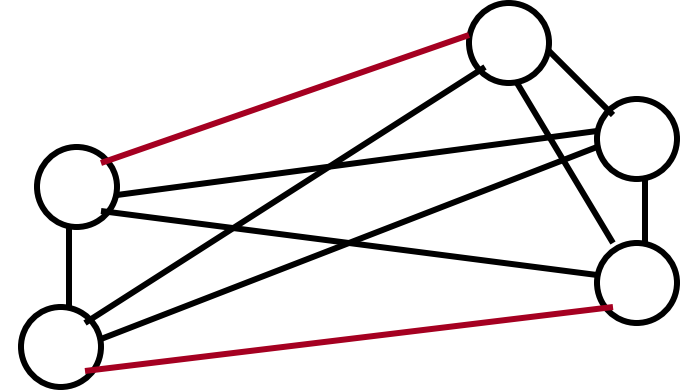

NOT PLANAR

10 vertices, 13 edges

$13 > 2(10) - 4$. Fails test for necess. condition

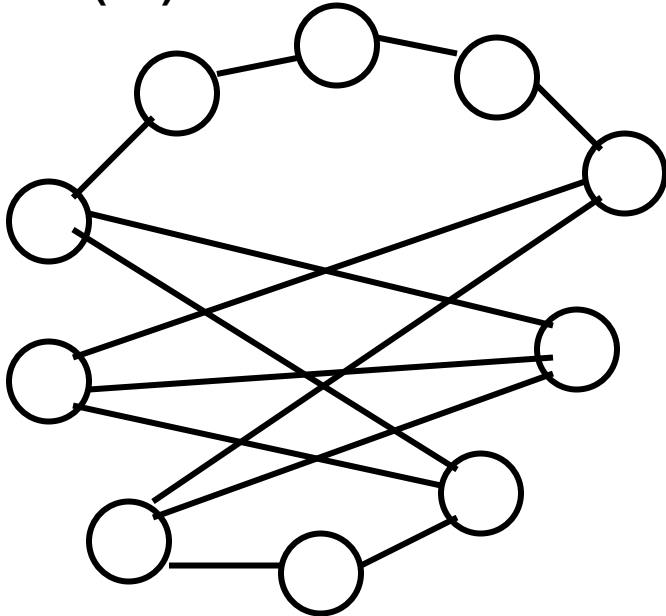

After
Smoothening

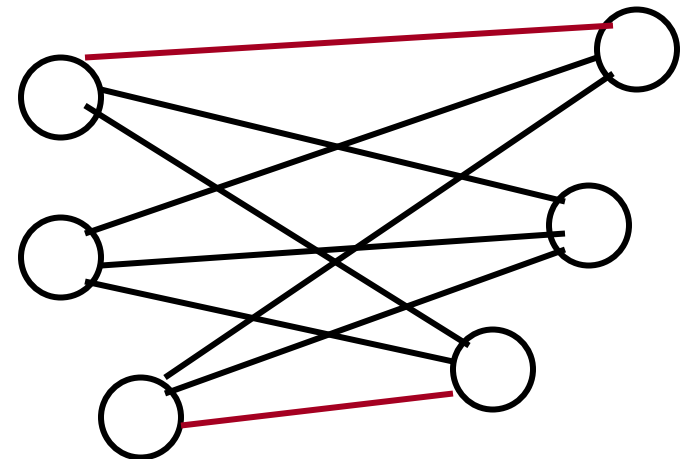

NOT PLANAR

Planar Graph (3)

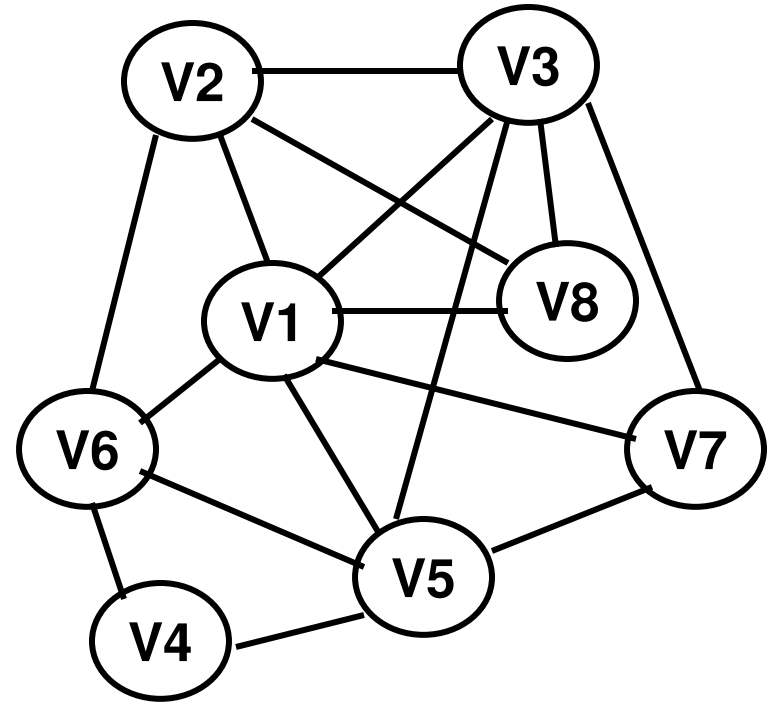
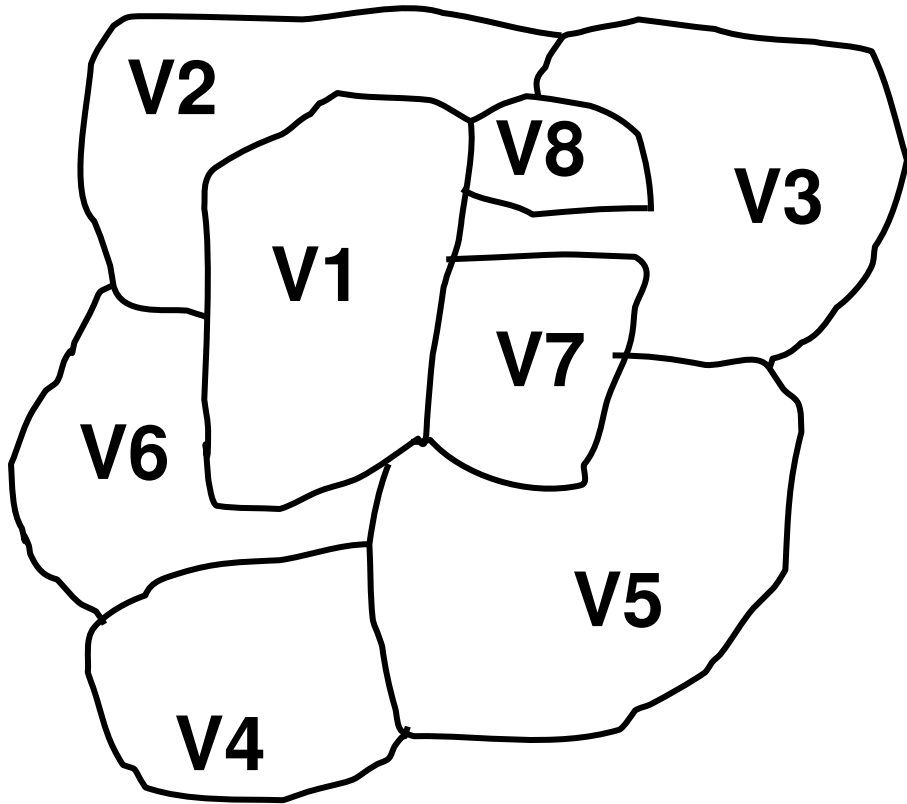

For every two regions that have a common border, we add an edge between the corresponding vertices in the graph.

8 vertices; 16 edges; there is a triangle
 $16 < 3(8) - 6$; $16 < 18$.
So, it passes the necessary condition for planar graph

Planar Graph (4)

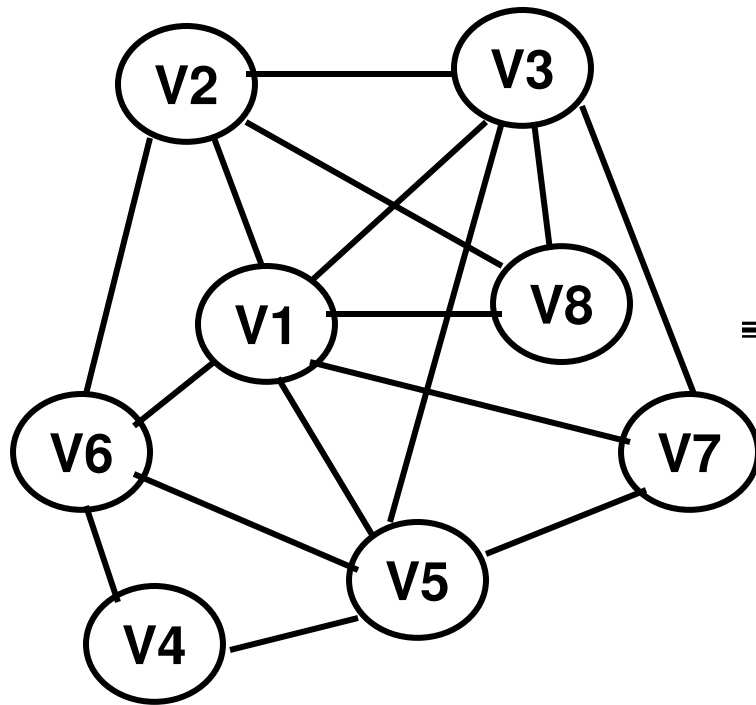

After
Smoothing

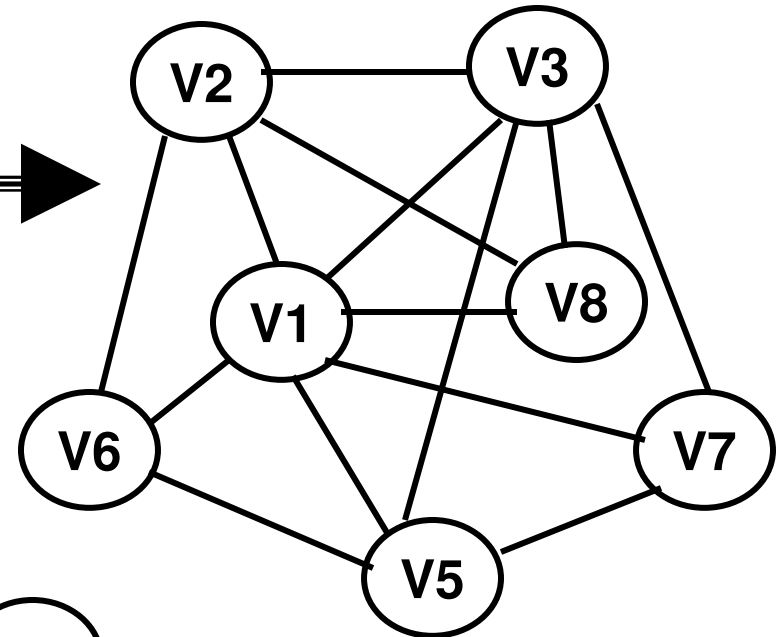

After smoothing, among the remaining 7 vertices, there cannot be a K_5 because there are three vertices V_6 , V_7 and V_8 of degree less than 4.

There is NO K_5 and NO $K_{3,3}$. Hence, the graph is PLANAR.



Among the remaining 7 vertices, V_6 , V_7 and V_8 are the three vertices that do not have any edge between them. There are edges $V_2 - V_5$; $V_2 - V_1$; $V_2 - V_3$; $V_1 - V_5$. Hence, $\{V_6, V_7, V_8\}$ are the only Disjoint subset; there cannot be another disjoint subset.

Layered Graph for Planarity

- We need sufficient space to construct a planar network (e.g., roads in a city). If it becomes too congested to layout roads without intersection (at points other than the street intersections), then we have to opt for a multi-layer network (with nodes distributed across the different layers), with the sub graph in each layer being planar.
- This is the model that has been recently proposed to avoid congestion and handle population growth in a limited space in the city of Tokyo (as a multi-layered city).

The following two results have been arrived at for the lower and upper bounds. The lower bound is the same in both cases.

Let m be the # edges and n be the # vertices.

$$\left\lceil \frac{m}{3n-6} \right\rceil \leq \Theta(G) \leq \left\lfloor \sqrt{\frac{m}{3}} + \frac{3}{2} \right\rfloor$$

$$\left\lceil \frac{m}{3n-6} \right\rceil \leq \Theta(G) \leq \left\lfloor \frac{k_{\max}}{2} \right\rfloor$$

Planar Graph Problem

- Consider a non-planar network with 1,000 nodes and 10,500 edges; the maximum degree for any node in the network is 100. Determine the minimum and maximum number of layers that need to be constructed to transform the non-planar network to a multi-layer planar network.

$$\left\lceil \frac{10,500}{3 * 1000 - 6} \right\rceil \leq \Theta(G) \leq \left\lfloor \frac{100}{2} \right\rfloor \quad 4 \leq \Theta(G) \leq 50$$

$$\left\lceil \frac{10,500}{3 * 1000 - 6} \right\rceil \leq \Theta(G) \leq \left\lfloor \sqrt{\frac{10,500}{3}} + \frac{3}{2} \right\rfloor \quad 4 \leq \Theta(G) \leq 61$$

**We pick the maximum of the two upper bounds 50 and 61, which is 61.
Hence, the minimum and maximum number of layers are 4 and 61 respectively.**

Protein Folding

- Protein folding is the process by which a protein transforms from a random coil (sequence of amino acids: linear polypeptide chain) to its characteristic 3-dimensional structure that is essential to its expected function.
- The correct three-dimensional structure is essential to function, although some parts of functional proteins may remain unfolded.
- Failure to fold into native structure generally produces inactive proteins, but in some instances misfolded proteins have modified or toxic functionality.
- When modeled as a graph, the more flat (linear chain) is the graph, the less the folding and vice-versa.

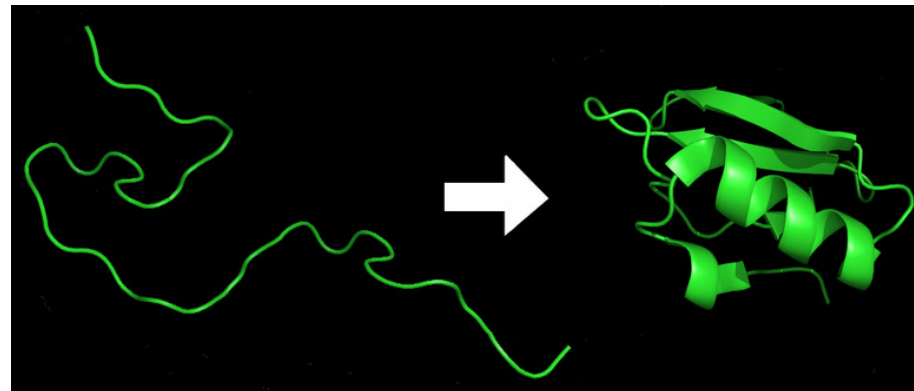

Source: Wikipedia

Estrada Index of Graphs

- The Estrada Index can be used to determine the degree of folding of a protein.
 - Larger the Estrada Index, the larger the folding.

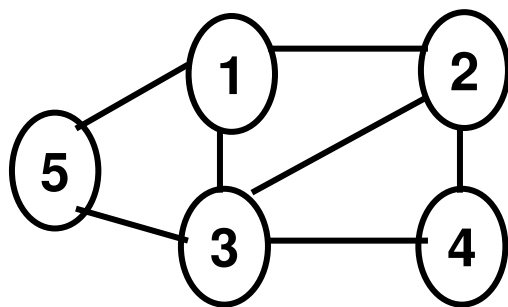

$$A = \begin{bmatrix} 0 & 1 & 1 & 0 & 1 \\ 1 & 0 & 1 & 1 & 0 \\ 1 & 1 & 0 & 1 & 1 \\ 0 & 1 & 1 & 0 & 0 \\ 1 & 0 & 1 & 0 & 0 \end{bmatrix}$$

	e^{λ_j}
$\lambda_1 = -1.618$	0.2
$\lambda_2 = -1.473$	0.23
$\lambda_3 = -0.463$	0.63
$\lambda_4 = 0.618$	1.852
$\lambda_5 = 2.935$	18.654

$$EE(G) = \sum_{j=1}^n e^{\lambda_j}$$

$$EE(G) = 21.56$$

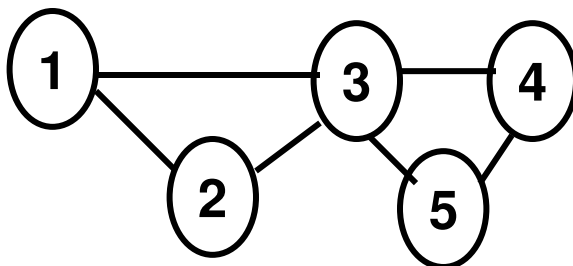

$$A = \begin{bmatrix} 0 & 1 & 1 & 0 & 0 \\ 1 & 0 & 1 & 0 & 0 \\ 1 & 1 & 0 & 1 & 1 \\ 0 & 0 & 1 & 0 & 1 \\ 0 & 0 & 1 & 1 & 0 \end{bmatrix}$$

	e^{λ_j}
$\lambda_1 = -1.5616$	0.211
$\lambda_2 = -1$	0.369
$\lambda_3 = -1$	0.369
$\lambda_4 = 1$	2.71
$\lambda_5 = 2.5616$	12.856

$$EE(G) = 16.51$$

Estrada Index of Star and Chain

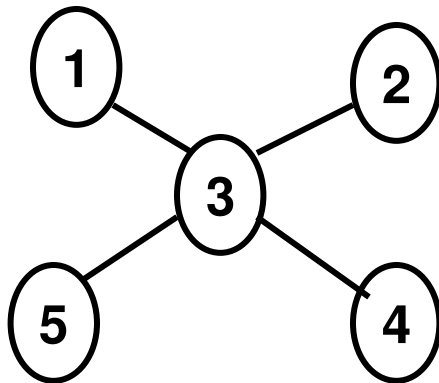

$$A = \begin{bmatrix} 0 & 0 & 1 & 0 & 0 \\ 0 & 0 & 1 & 0 & 0 \\ 1 & 1 & 0 & 1 & 1 \\ 0 & 0 & 1 & 0 & 0 \\ 0 & 0 & 1 & 0 & 0 \end{bmatrix}$$

$\lambda_1 = -2$

$\lambda_2 = 0$

$\lambda_3 = 0$

$\lambda_4 = 0$

$\lambda_5 = 2$

 e^{λ_j}

0.136

1

1

1

7.344

$EE(G) = 10.48$

$$EE(G) = \sum_{j=1}^n e^{\lambda_j}$$

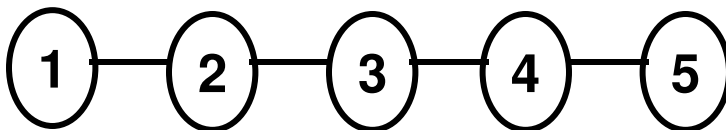

$$\begin{bmatrix} 0 & 1 & 0 & 0 & 0 \\ 1 & 0 & 1 & 0 & 0 \\ 0 & 1 & 0 & 1 & 0 \\ 0 & 0 & 1 & 0 & 1 \\ 0 & 0 & 0 & 1 & 0 \end{bmatrix}$$

$\lambda_1 = -1.7321$

$\lambda_2 = -1$

$\lambda_3 = 0$

$\lambda_4 = 1$

$\lambda_5 = 1.7321$

 e^{λ_j}

0.178

0.369

1

2.71

5.622

$EE(G) = 9.88$

Network Returnability

- By computing Estrada Index on directed networks, we can determine how much of the information departing from a node in the network returns to it.
- Estrada Index is the weighted sum of the number of walks of lengths k ($k = 0, 1, 2, \dots$) that start and end at each of the nodes in the network.
- In the context of network returnability, we define the Estrada Index as: $Z(D) = EE(D) - n$.

Returnability Equilibrium Constant $K_r = \frac{Z(D)}{Z(U)}$

where $Z(D)$ and $Z(U)$ are the Estrada Index of Network Returnability values for a directed network D and its undirected version U (with symmetric links) respy.

$$0 \leq K_r \leq 1$$

$K_r = 0$ for a directed graph with no cycles; $K_r = 1$ for a directed graph with all bi-directional edges

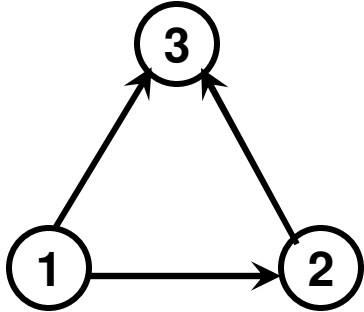

0	1	1
0	0	1
0	0	0

λ_j	e^{λ_j}
0	1
0	1
0	1

$$Z(D) = EE(D) - n = \sum_{j=1}^n e^{\lambda_j} - n$$

$$Z(D) = 3 - 3 = 0$$

$$K_r = 0 / 5.082 = 0$$

**Examples:
Network
Returnability**

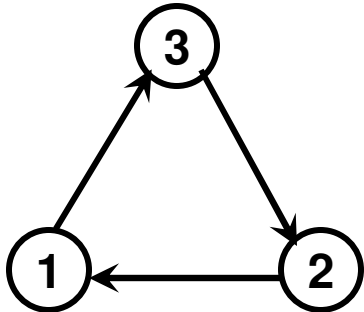

0	0	1
1	0	0
0	1	0

λ_j	e^{λ_j}
1	2.71
-0.5-0.866i	$e^{-0.5} (\cos(-0.866) + i \sin(-0.866))$
-0.5+0.866i	$e^{-0.5} (\cos(0.866) + i \sin(0.866))$

e^{λ_j}	Note: $\sin(-x) = -\sin(x)$ $\cos(-x) = \cos(x)$
2.71	
$e^{-0.5} (\cos(-0.866) + i \sin(-0.866))$	
$e^{-0.5} (\cos(0.866) + i \sin(0.866))$	

$$e^{a+bi} = e^a \cdot e^{bi} = e^a (\cos b + i \sin b)$$

$$EE(D) = 2.71 + e^{-0.5} \{ \cos(-0.866) + \cos(0.866) \}$$

$$= 2.71 + e^{-0.5} \{ \cos(0.866) + \cos(0.866) \}$$

$$= 2.71 + 2 \cdot e^{-0.5} \cdot \cos(0.866)$$

$$= 2.71 + 2 \cdot e^{-0.5} \cdot 1 = 2.71 + 2 \cdot 0.6074$$

$$= 3.925$$

$$Z(D) = EE(D) - 3 = 0.925$$

$$K_r = 0.925 / 5.082 = 0.182$$

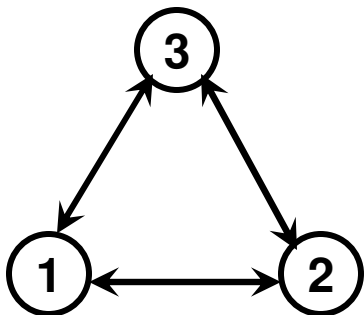

0	1	1
1	0	1
1	1	0

λ_j	e^{λ_j}
-1	0.369
-1	0.369
2	7.344

$$Z(D) = 8.082 - 3 = 5.082$$

$$K_r = 5.082 / 5.082 = 1.0$$

Returnability Equilibrium Constant of Real Networks

• Networks	- log(Kr)	Kr
– Thesaurus	1.45	0.2356
– Prison Inmates	0.90	0.4077
– US airports	0.00	1.0
– Neuron network (abundant with activator-sink links)		
• Trans Elegans	6.11	0.0022
– Food webs (indicating strong prey-predator flow)		
• LittleRock	14.66	0.0000004
• Skipwith	7.42	0.0006

Note that directed networks having high returnability will also have a positive correlation between the in-degree and out-degree of nodes (due to the increased chances of the information leaving a node to flow back into the node). On the other hand, directed networks having low returnability are expected to have a negative correlation between the in-degree and out-degree of nodes, as in such networks, a node is more likely to have either a high in-degree (only information flows in) or high out-degree (only info. flows out)

Eigen Values of an almost Bipartite Network

- There are even number of vertices.
- Let $\lambda_1, \lambda_2, \lambda_3, \dots, \lambda_n$ be the n Eigenvalues of an n -node network.
- For any $j = 1, 2, \dots, n/2$, if $\lambda_j = |-\lambda_{n-j+1}|$, then the network is almost bi-partite.

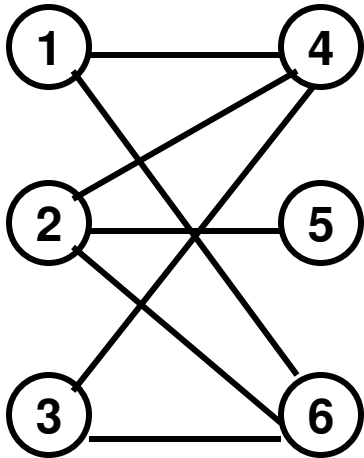

0	0	0	1	0	1
0	0	0	1	1	1
0	0	0	1	0	1
1	1	1	0	0	0
0	1	0	0	0	0
1	1	1	0	0	0

Eigenvalues

-2.5243

-0.7923

0

0

0.7923

2.5243

Bipartite Graphs

Bipartivity Check

- A bi-partite graph is the one that has two partitions V_1 and V_2 of its vertices such that
 - $V_1 \cup V_2 = V$; $V_1 \cap V_2 = \Phi$.
 - No edges within V_1 and within V_2 .
 - All edges are those connecting V_1 and V_2 .

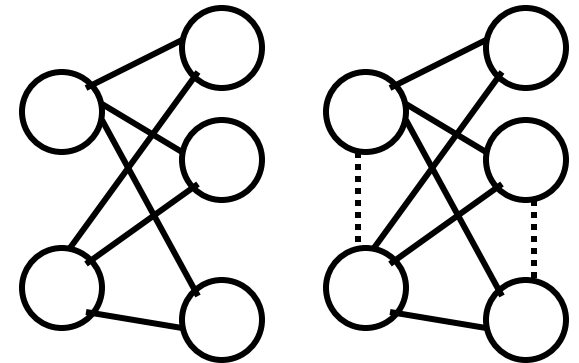

There should be NO odd length cycles in a truly bi-partite network

- Graphs can be considered close to bi-partite if there are few edges (not a significant number) called the frustrated edges that connect vertices within V_1 and/or V_2 .

Computing the Bipartite Measure

Compute the Eigenvalues ($\lambda_1, \lambda_2, \lambda_3, \dots, \lambda_n$) of the $n \times n$ adjacency matrix.

$$b_S(G) = \frac{\sum_{j=1}^n \cosh(\lambda_j)}{\sum_{j=1}^n \cosh(\lambda_j) + \sum_{j=1}^n \sinh(\lambda_j)}$$

For a “truly” bi-partite graph, $b_S(G) = 1$; the sinh terms add to 0.

For a “close-to” bi-partite graph, $b_S(G) < 1$; the sinh terms add up to some small positive value.

Bipartivity Measure: Examples

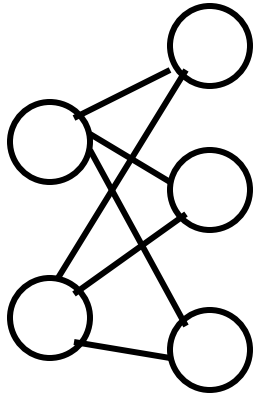

$$b_S(G) = 1.0$$

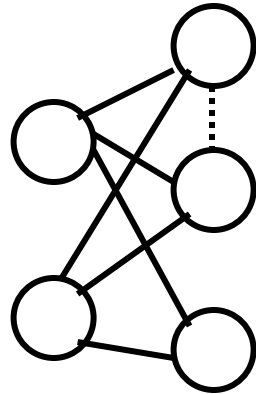

$$b_S(G) = 0.829$$

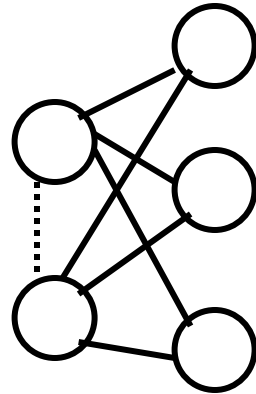

$$b_S(G) = 0.769$$

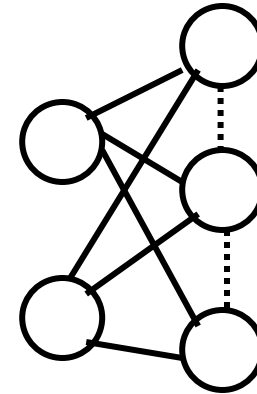

$$b_S(G) = 0.731$$

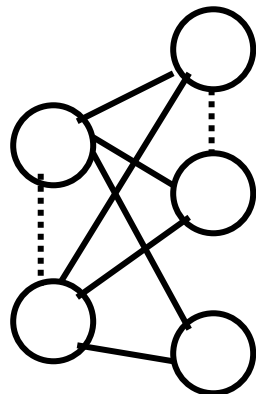

$$b_S(G) = 0.692$$

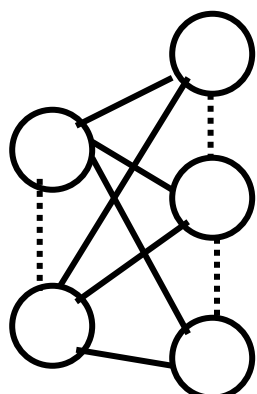

$$b_S(G) = 0.645$$

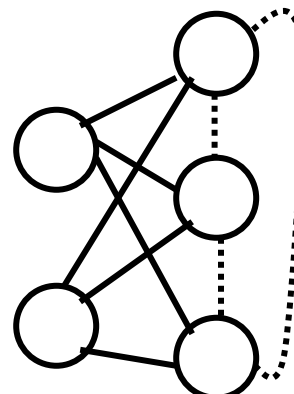

$$b_S(G) = 0.645$$

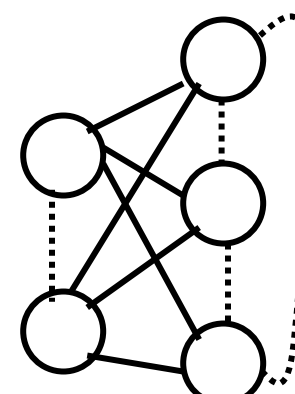

$$b_S(G) = 0.597$$

For a given number of frustrated links, a larger bipartivity measure is observed if more of the frustrated links are present in the network with the larger subset.

Bipartivity of Real Networks

Type: Information

Network	Bipartivity Measure
SciMet	0.500
Roget	0.529

Type: Social

Network	Bipartivity Measure
Drugs	0.500
Corporate Elite	0.500
Karate Club	0.597
Saw Mill	0.749

Type: Food webs

Network	Bipartivity Measure
Coachella	0.500
El Verde	0.500
Grassland	0.743
Stony stream	0.815

Type: PPIs

Network	Bipartivity Measure
Yeast	0.500
Human	0.576
H. Pylori	0.711
A. Fulgidus	0.976

Type: Transcription

Network	Bipartivity Measure
Urchin	0.618
E. Coli	0.831
Yeast	0.960

Type: Technological

Network	Bipartivity Measure
USAir97	0.500
Internet	0.502
Electronic3	0.952

Identifying Bipartite Subsets using Eigenvalue and Eigenvector

- We identify the smallest Eigenvalue (most likely a negative value), hereafter called the bi-partite Eigenvalue, and its corresponding Eigenvector, hereafter called the bi-partite Eigenvector.
- The values in the bi-partite Eigenvector will be positive and negative.
 - The node IDs whose entries are of the same sign in the bi-partite Eigenvector form the two subsets.
 - The vertices that are of the same sign are more likely not to have links between them, and are more likely to have links with vertices of the other sign.
 - Each of the two subsets will have the minimum (or zero, if possible) number of frustrated links. Most of the links are likely to be between the vertices in the two subsets.

Identifying Bipartite Subsets using Eigenvalue and Eigenvector: Ex. 1 (1)

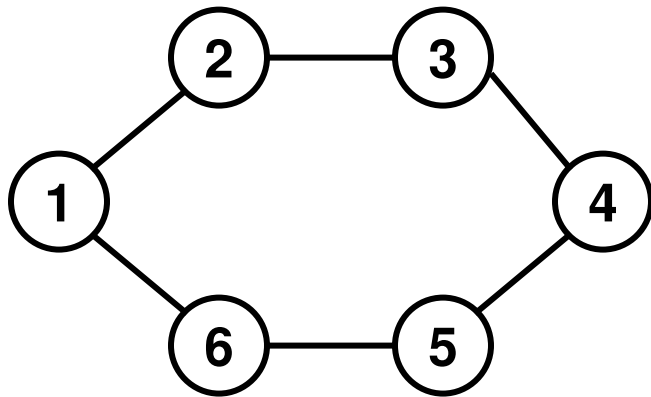

	1	2	3	4	5	6
1	0	1	0	0	0	1
2	1	0	1	0	0	0
3	0	1	0	1	0	0
4	0	0	1	0	1	0
5	0	0	0	1	0	1
6	1	0	0	0	1	0

Based on the lowest Negative Eigenvalue -2:

1	-1
2	1
3	-1
4	1
5	-1
6	1

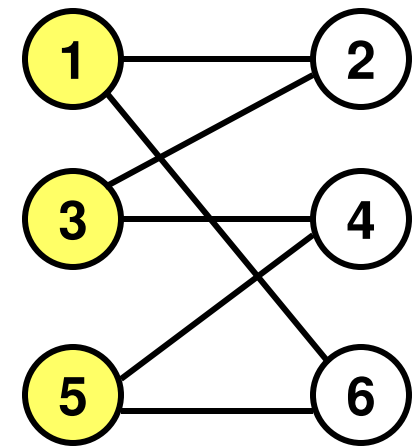
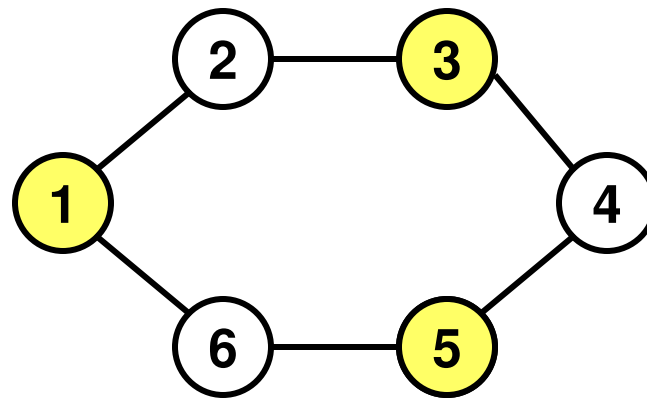

Identifying Bipartite Subsets using Eigenvalue and Eigenvector: Ex. 1 (2)

Eigenvalue, λ	$\cosh(\lambda)$	$\sinh(\lambda)$
-2	3.7622	-3.6269
-1	1.5431	-1.1752
-1	1.5431	-1.1752
1	1.5431	1.1752
1	1.5431	1.1752
2	3.7622	-3.6269

Total	13.6968	0

$$b_S(G) = \frac{\sum_{j=1}^n \cosh(\lambda_j)}{\sum_{j=1}^n \cosh(\lambda_j) + \sum_{j=1}^n \sinh(\lambda_j)}$$

$$b_S(G) = \frac{13.6968}{(13.6968 + 0)} = 1.0$$

Identifying Bipartite Subsets using Eigenvalue and Eigenvector: Ex. 2 (1)

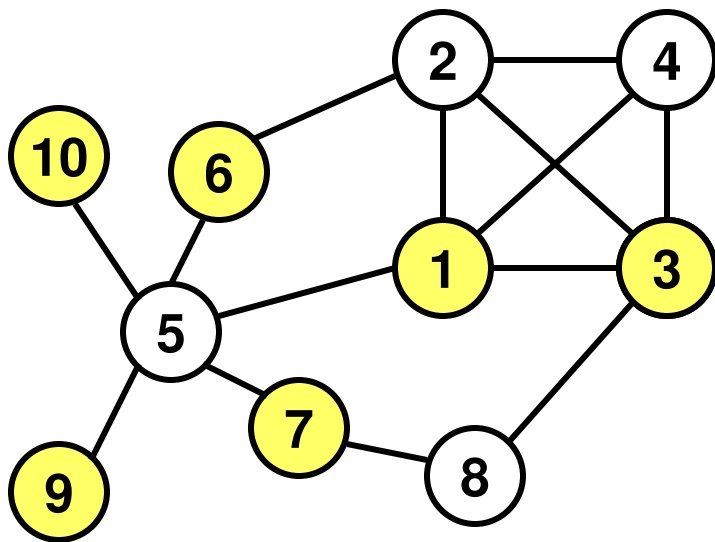

	1	2	3	4	5	6	7	8	9	10
1	0	1	1	1	1	0	0	0	0	0
2	1	0	1	1	0	1	0	0	0	0
3	1	1	0	1	0	0	0	1	0	0
4	1	1	1	0	0	0	0	0	0	0
5	1	0	0	0	0	1	1	0	1	1
6	0	1	0	0	1	0	0	0	0	0
7	0	0	0	0	1	0	0	1	0	0
8	0	0	1	0	0	0	1	0	0	0
9	0	0	0	0	1	0	0	0	0	0
10	0	0	0	0	1	0	0	0	0	0

Identifying Bipartite Subsets using Eigenvalue and Eigenvector: Ex. 2 (2)

Based on the lowest Negative Eigenvalue -2.4870836366555125 :

1	1.4787537545980032
2	-1.187138860314116
3	0.19014161045039232
4	-0.1937033791843519
5	-2.4870836366555196
6	1.477321648061068
7	1.2295096130605534
8	-0.570809603098033
9	1
10	1

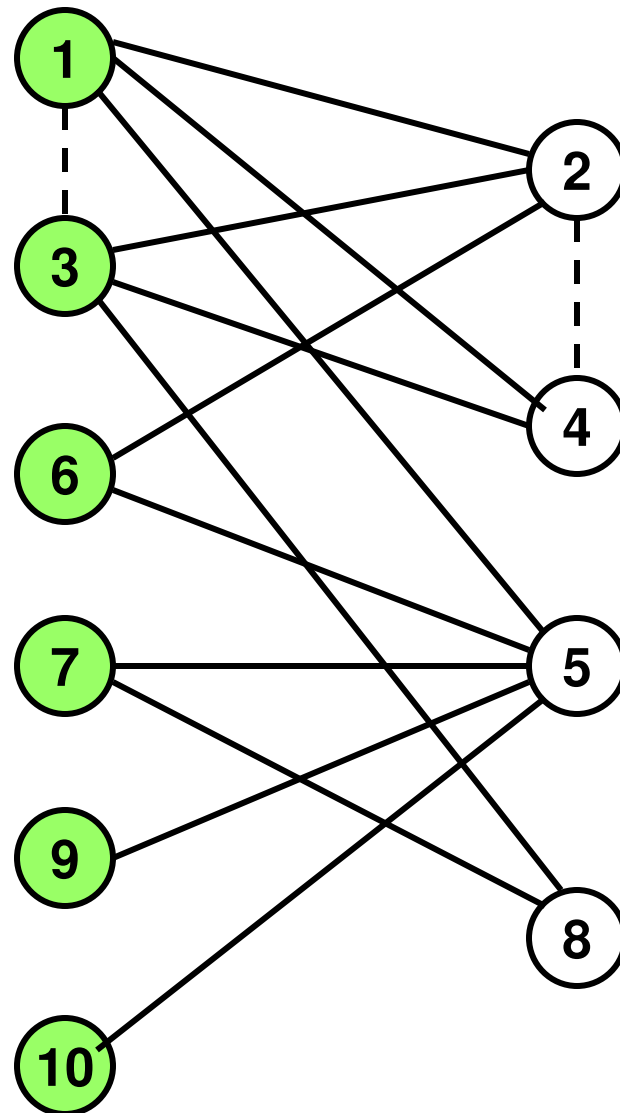

Identifying Bipartite Subsets using Eigenvalue and Eigenvector: Ex. 2 (3)

Eigenvalue, λ	$\cosh(\lambda)$	$\sinh(\lambda)$
-2.4871	6.0547	-5.9716
1.6828	2.7832	-2.5974
-1.3098	1.9877	-1.7178
-0.8564	1.3897	-0.9650
-0.3741	1.0708	-0.3829
0	1.0	0
0.3197	1.0515	0.3252
1.1131	1.6862	1.3576
1.8880	3.3788	3.2274
3.3893	14.839	14.8057
<hr/>		
Total	35.2416	8.0812

$$b_S(G) = \frac{\sum_{j=1}^n \cosh(\lambda_j)}{\sum_{j=1}^n \cosh(\lambda_j) + \sum_{j=1}^n \sinh(\lambda_j)}$$

$$b_S(G) = \frac{35.2416}{(35.2416 + 8.0812)} = 0.8135$$

Bipartite Partition Detection: Digraph

- When confronted with a directed graph, first transform the directed graph to an undirected graph and determine the two partitions as explained previously using the Eigenvector approach.
- After identifying the partitions, restore the directions of the edges.
- In a directed graph, the edges typically point from one set of vertices to the other set of vertices.
 - There could be scenarios where the edges could point in the reverse direction; as long as we know the direction of the edges, we could restore them after determining the two partitions.

Digraph Bipartivity Detection: Example (1)

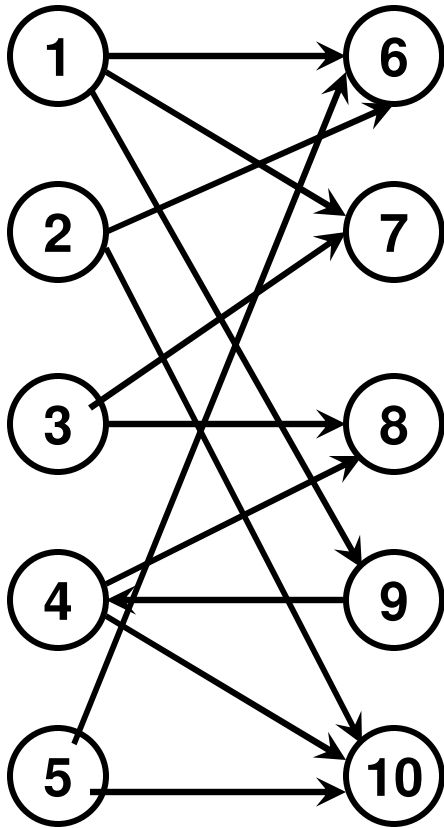

	1	2	3	4	5	6	7	8	9	10
1	0	0	0	0	0	1	1	0	1	0
2	0	0	0	0	0	1	0	0	0	1
3	0	0	0	0	0	0	1	1	0	0
4	0	0	0	0	0	0	0	1	0	1
5	0	0	0	0	0	1	0	0	0	1
6	1	1	0	0	1	0	0	0	0	0
7	1	0	1	0	0	0	0	0	0	0
8	0	0	1	1	0	0	0	0	0	0
9	1	0	0	1	0	0	0	0	0	0
10	0	1	0	1	1	0	0	0	0	0

Digraph Bipartivity Detection: Example (2)

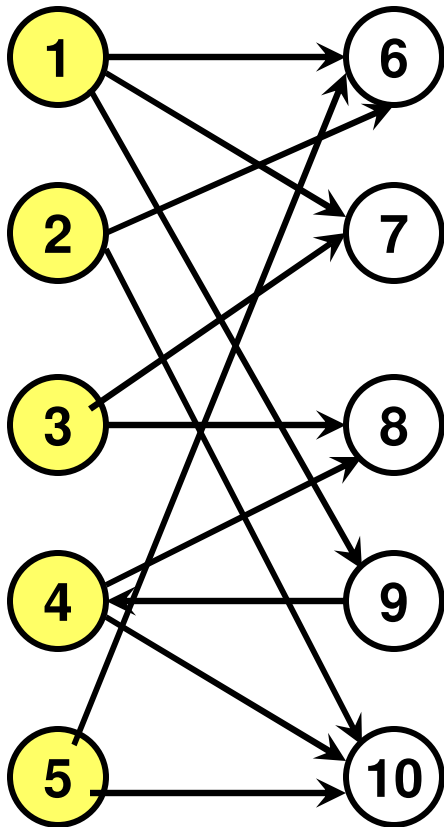

Based on the lowest Negative Eigenvalue -2.4998281017161057:

1	-0.8997180792493449
2	-0.8000550112333811
3	-0.42348238246099357
4	-0.8997180792493445
5	-0.8000550112333811
6	1
7	0.5293165801288399
8	0.5293165801288398
9	0.7198239580007104
10	1

Communicability in a Network

- For any two nodes r and s , the communicability of a pair of nodes r and s is $C(r,s)$ - the weighted sum of the number of walks between these two nodes of lengths $l = 1, 2, \dots, \infty$; the weights are $1/l!$.

$$C(r,s) = \sum_{l=1}^{\infty} \frac{(A^l)_{rs}}{l!}$$

In closed form,

$$C(r,s) = \sum_{j=1}^n \varphi_j(r) \varphi_j(s) e^{\lambda_j}$$

where $\varphi_j(i)$ is the i th entry of the j th Eigenvector associated with Eigenvalue λ_j

Communicability of a Node r

$$C(r) = \sum_{s=1}^n C(r,s)$$

Example 1: Network Communicability (1)

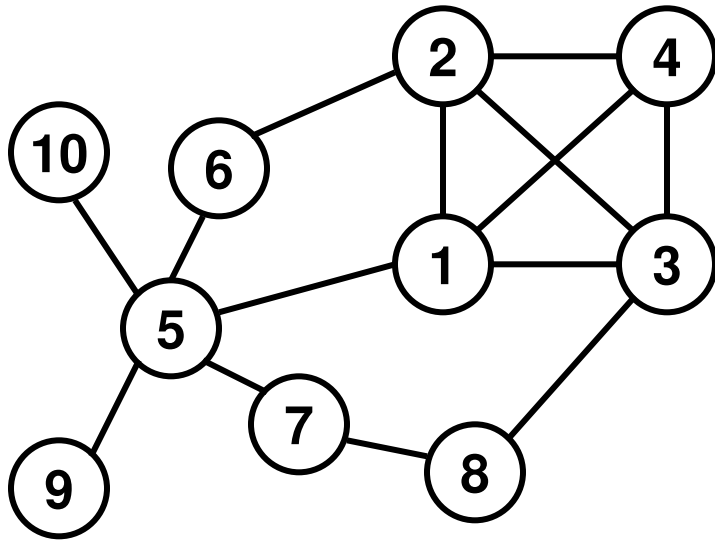

	1	2	3	4	5	6	7	8	9	10
1	0	1	1	1	1	0	0	0	0	0
2	1	0	1	1	0	1	0	0	0	0
3	1	1	0	1	0	0	0	1	0	0
4	1	1	1	0	0	0	0	0	0	0
5	1	0	0	0	0	1	1	0	1	1
6	0	1	0	0	1	0	0	0	0	0
7	0	0	0	0	1	0	0	1	0	0
8	0	0	1	0	0	0	1	0	0	0
9	0	0	0	0	1	0	0	0	0	0
10	0	0	0	0	1	0	0	0	0	0

Node IDs: 1, 2, ..., 10

EigenValue	1	2	3	4	5	6	7	8	9	10
3.389	5.38	5.18	5.05	4.61	3.39	2.53	1.58	1.96	1	1
1.888	-0.19	-0.61	-0.79	-0.85	1.89	0.67	1.08	0.15	1	1
1.113	1.13	1.87	-2.33	0.6	1.11	2.68	-4.58	-6.21	1	1
0.3197	0.95	-1.07	0.35	0.71	0.32	-2.35	-0.5	-0.48	1	1
0	0	0	0	0	0	0	0	0	-1	1
-0.3741	-1	0.23	0.94	-0.41	-0.37	0.39	-1.25	0.84	1	1
-0.8564	-2.71	1.12	1.19	3.25	-0.86	-0.31	1.75	-0.64	1	1
-1.3098	0.55	4.71	-0.46	-3.67	1.31	-2.6	1.76	-1	1	1
-1.6828	4.16	1.79	-8.81	1.69	-1.68	-0.06	-3.26	7.18	1	1
-2.4871	1.48	-1.18	0.19	-0.19	-2.487	1.48	1.23	-0.57	1	1

Eigen Vectors

Example 1: Network Communicability (2)

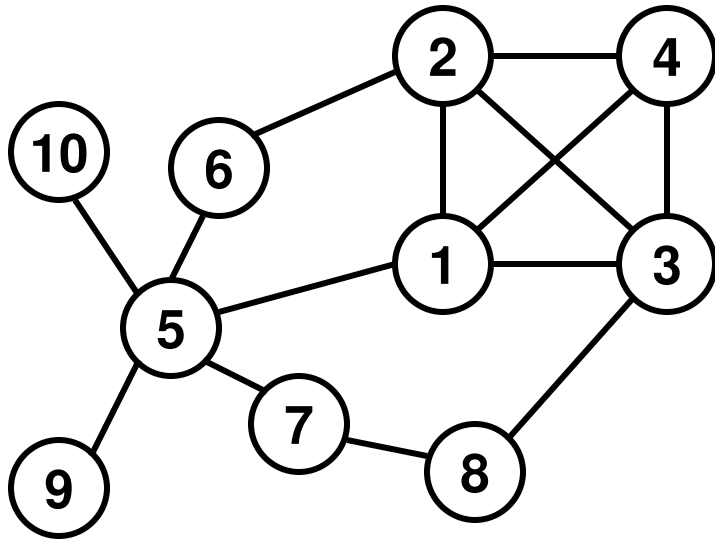

Even though node 5 has the highest degree (5 links), its communicability is less than that of the nodes in the clique (1, 2, 3, 4). The links to peripheral nodes such as 9 and 10 does not make any significant contributions to the communicability of node 5. Hence, to have high communicability, it is better for a node to be part of a clique and/or connected with nodes having high degree.

Each of nodes 7 and 8 have the same degree; but, since Node 8 is connected to a node in the clique, node 8 has high communicability.

The relative closeness of node 6 to a high degree node 5 helps node 2 to gather high communicability compared to node 3 that is connected to node 8 which is in turn connected to a low-degree node (node 7).

NodeID	
1	5035
2	4837
3	4750
4	4306
5	3210
6	2361
8	1915
7	1556
9	952
10	952

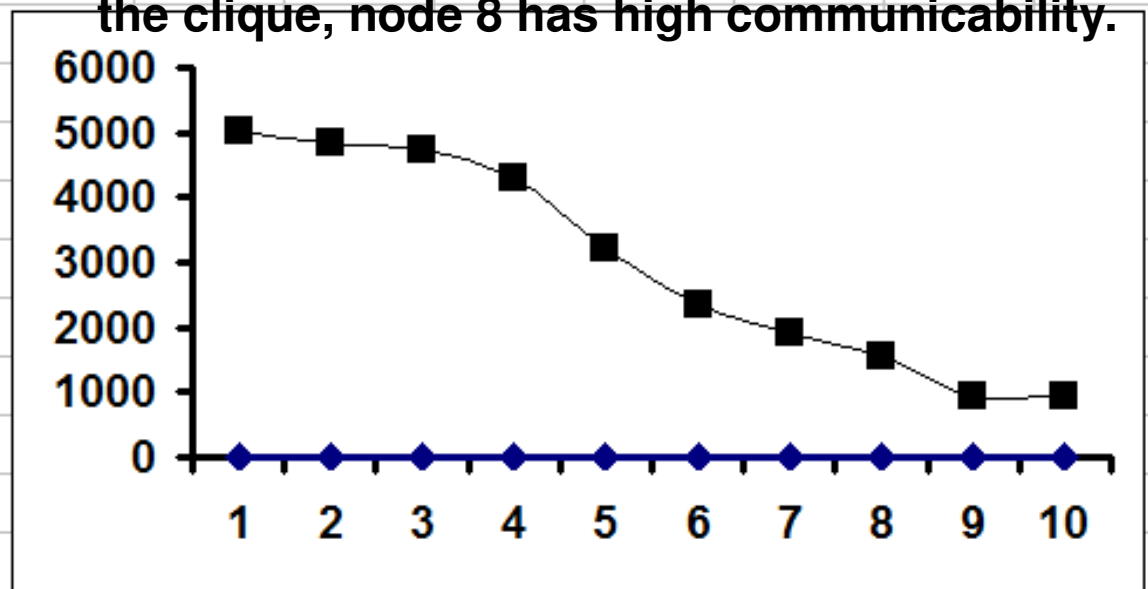

Example 1: Network Communicability (3)

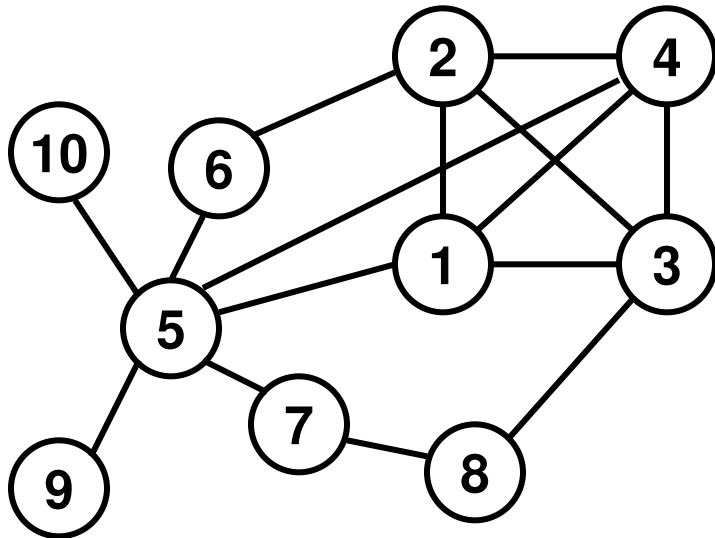

The communicability of node 5 has increased with the additional connection to the clique and the connections to the other nodes further contributing to it.

Note that the communicability of the nodes in the clique (1, 2, 3, 4) has reduced a bit as the domination of node 5 increases.

We add a link 4 – 5, making Node 5 connected to 2 of the 4 nodes in the 4-node clique

NodeID	
1	4250
4	4250
2	3865
5	3833
3	3800
6	2055
8	1576
7	1553
9	1032
10	1032

